



Заказать: www.gassensor.ru (495) 123-45-14 info@gassensor.ru

MOLECULAR PROPERTY SPECTROMETER™ (MPS™) A2L REFRIGERANT GAS SENSOR USER MANUAL



A2L IS
Intrinsically Safe Form
Factor



A2L Mini
Standard Form Factor

Notices

SM-UM-0004-11

Copyright © 2018-2022 Nevada Nanotech Systems Inc. All rights reserved.

1395 Greg Street, Suite 102

Sparks, Nevada 89431

All Rights Reserved

This publication is protected by copyright and all rights are reserved. No part of it may be reproduced or transmitted by any means or in any form, without prior consent in writing from NevadaNano.

The information in this document has been carefully checked and is believed to be accurate. However, changes are made periodically. These changes are incorporated in the newer publication editions. NevadaNano may improve and/or change products described in this publication at any time. Due to continuing system improvements, NevadaNano is not responsible for inaccurate information which may appear in this manual. For the latest product updates, consult the NevadaNano web site at www.nevadanano.com. In no event will NevadaNano be liable for direct, indirect, special exemplary, incidental, or consequential damages resulting from any defect or omission in this document, even if advised of the possibility of such damages.

In the interest of continued product development, NevadaNano reserves the right to make improvements in this document and make the products it describes at any time, without notices or obligation.

The Molecule logo is a trademark of Nevada Nanotech Systems Inc. Use of the logos for commercial purposes without the prior written permission of NevadaNano may constitute trademark infringement and unfair competition in violation of federal and state laws.

NevadaNano, the Molecule logo, Molecular Property Spectrometer, and MPS are trademarks of Nevada Nanotech Systems Inc.

Other trademarks and trade names may be used in the document to refer to either the entities claiming the marks and names or their products. Nevada Nanotech Systems Inc. disclaims any proprietary interest in trademarks and trade names other than its own.



Please Recycle

Shipping materials are recyclable. Please save them for later use, or dispose of them appropriately.

Revision History

Version	Issue Date (DD/MM/YYYY)	Change
SM-UM-0004-01	30/01/2020	Initial release
SM-UM-0004-02	19/05/2020	Added section 4.1 and included CO ₂ . Added section 5 to outline CDs and electrical pinouts
SM-UM-0004-03	11/06/2020	Updated the table in section 4 to include updated list of poisons.
SM-UM-0004-04	30/09/2020	Typographical errors corrected
SM-UM-0004-05	11/03/2021	Update dimensions of S4 package so that pin locations relative to the center of the package are shown
SM-UM-0004-06	24/03/2021	Updated voltage ranges to 3.3-5V +/- 5%
SM-UM-0004-07	27/05/2021	Added note in electromechanical integration section for termination of analog out pin.
SM-UM-0004-08	31/12/2021	Certificates of compliance removed. Table of contents updated.
SM-UM-0004-09	15/04/2022	Updated with change from A2L FW3.x.x.x to A2L FW4.1.x.x
SM-UM-0004-10	18/05/2022	Fixed typos. Updated CO ₂ cross sensitivity trigger value
SM-UM-0004-11	07/06/2022	Added information about analog out + auto start + UART
SM-UM-0004-12	13/09/2022	Updated table in section 3

Contents

1.	How the MPS A2L Refrigerant Gas Sensor.....	5
2.	Communicating with the MPS A2L Refrigerant Gas Sensor.....	5
2.1.	Serial (UART) Communication.....	5
2.1.1.	Data Representation.....	5
2.1.2.	Protocol Specification.....	6
2.1.3.	Checksum Calculation.....	8
2.1.4.	Startup and Measurement Sequence.....	9
2.1.5.	Command Table.....	13
2.1.6.	Command Descriptions.....	13
2.2.	Sensor Analog Output Mode.....	17
2.2.1.	Analog Out Electrical Integration.....	18
2.2.2.	Using Analog Output and UART with Auto Start.....	19
2.3.	Testing the MPS A2L Refrigerant Gas Sensor.....	20
2.4.	Setup #1: Testing in a Tank.....	21
2.5.	Setup #2: Testing in Various Environmental Conditions.....	22
3.	Operating Conditions for the MPS A2L Refrigerant Gas Sensor.....	24
3.1.	Response to Other Gases.....	25
3.1.1.	Carbon Dioxide (CO ₂).....	25
3.2.	Hazardous Locations and System Integration.....	25
4.	Environmental Faults and Conditions Affecting Accuracy.....	25
5.	Electromechanical Integration.....	26
5.1.	General Guidelines.....	26
5.2.	A2L Mini Form Factor Critical Dimensions and Pinout.....	27
5.3.	A2L IS Form Factor Critical Dimensions and Pinout.....	29
5.4.	MPS Mini PCB Mounting Guidelines.....	30
5.4.1.	Clearances from Heat-Generating Components.....	30
5.4.2.	Enclosure Opening to Sense the Presence of Gas.....	30
5.4.3.	Soldering the MPS Mini Sensor to a PCB.....	30

1. How the MPS A2L Refrigerant Gas Sensor Works

The MPS A2L Refrigerant Gas Sensor is a smart sensor with built-in environmental compensation that detects and accurately quantifies low-global-warming, mildly flammable (A2L) refrigerants used in HVAC applications. It is robust, extremely poison resistant, and comes factory calibrated. Sensor readings are output on a Universal Asynchronous Receiver and Transmitter (UART) digital bus or industry-standard analog output.

The MPS transducer is a micro-machined membrane with an embedded Joule heater and resistance thermometer. The MEMS transducer is mounted on a PCB and packaged inside a filtered enclosure that is permeable to ambient air. Presence of a flammable refrigerant gas causes changes in the thermodynamic properties of the air/gas mixture; these properties are measured by the transducer and processed by patent-pending algorithms to report an accurate concentration.

2. Communicating with the MPS A2L Refrigerant Gas Sensor

This section describes the software interface requirements for the MPS A2L Refrigerant Gas Sensor and is useful to system integrators when designing the sensor assembly into a final product.

The preferred method of communicating with the sensor is over the serial interface using the UART (Universal Asynchronous Receiver/Transmitter) protocol. Section 2.1 provides the necessary information for communicating using UART. Section 2.2 provides information for measuring sensor output via the analog voltage output pin.

2.1. Serial (UART) Communication

Communication with the system over the serial interface (UART) will allow an external user or system to execute the commands provided in the Command Table in Section 2.1.5. Users may also refer to the Command Descriptions in Section 2.1.6 for usage descriptions.

Serial connection parameters:

Parameter	Size
Baud Rate	38400
Data Size	8 bits
Parity	None
Stop Bit	1 bit

2.1.1. Data Representation

All integer values (16 bits or 32 bits) are represented in Little Endian format (LSB first). This means when an integer is transmitted on the serial interface, the least significant byte (LSB) is transmitted first and the most significant byte (MSB) is transmitted last.

Floating point numbers are represented in IEEE 754 format.

2.1.2. Protocol Specification

Communication to and from the MPS A2L Refrigerant Gas Sensor is made up of “packets.” The communication paradigm is that of “request” and “reply.” An external host sends a “request” packet to the sensor. The sensor returns a “reply” packet to the external host. A packet consists of a fixed size “header” and a variable length “payload.” It is possible for a packet to have no payload (length of zero) where a packet contains only a header. The payload, if any, typically consists of “parameters” for a request or “result” for a reply. Even when a reply does not contain any result, a reply is still sent with the header as an acknowledgement of the request.

Command Request

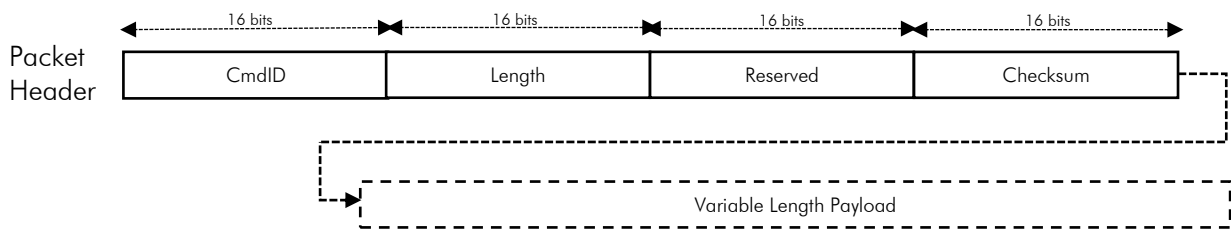

Figure 1: Request Packet Structure

The Request Packet (Figure 1) consists of the following fields:

Field	Size	Description
CmdID	2 Bytes	Command ID of this request (see Command Table in section 2.1.5). Although CmdID uses only 1 byte, it is extended to 2 bytes in the Request Header for alignment purposes.
Length	2 Bytes	Length of the Payload (0 if no payload)
Reserved	2 Bytes	Reserved for future use (zero filled)
Checksum	2 Bytes	Checksum of the entire packet
Variable Length Payload	variable	Command parameters for this request

Command Reply

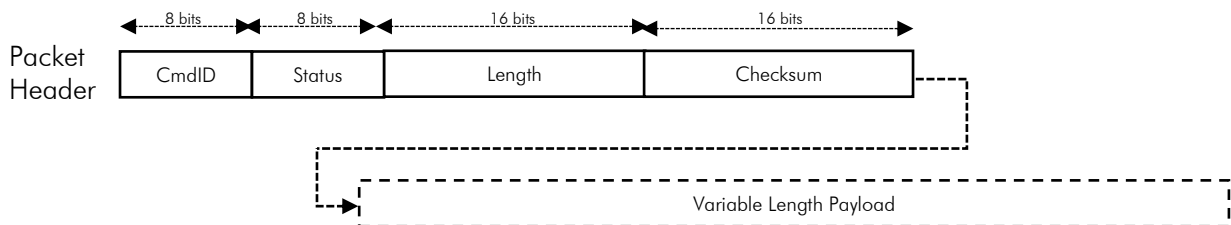

Figure 2: Reply Packet Structure

The Reply Packet (Figure 2) consists of the following fields:

Field	Size	Description
CmdID	1 Byte	Command ID (should match the original request)
Status	1 Byte	Return status of the request
Length	2 Bytes	Length of the Payload (0 if no payload)
Checksum	2 Bytes	Checksum of the entire packet
Variable Length Payload	variable	Command parameters for this request

The Status field consists of the following possible return values:

Fault	Fault Message	Explanation	%LFL Output	User action
0x00	OK	MPS is operating normally and has no errors	Normal	None
0x01	CRC_FAILED	Transmitted data failed checksum	N/A	Verify checksum calculation is correct. See Section 2.1.3.
0x02	BAD_PARAM	Illegal or bad parameters specified	N/A	Verify parameter given in command is correct.
0x03	EXE_FAILED	Execution of command failed	N/A	Contact support.
0x04	NO_MEM	Insufficient memory for operation	N/A	Contact support.
0x05	UNKNOWN_CMD	Unknown Command ID specified	N/A	Verify Command ID is correct. See Section 2.1.5.
0x07	INCOMPLETE_COMMAND	Incomplete or truncated command	N/A	Verify entire packet header and payload (if any) is fully sent.
0x20	HW_ERR_AO	Analog out malfunction (only if AO functionality enabled)	-100 %LFL	Contact support.
0x21	HW_ERR_VDD	Internal voltage regulator out of range	-100 %LFL	Supply 3.3-5.0 \pm 5% VDC. If this error persists for more than 5 cycles, this error will latch until the sensor is power cycled and supplied correct voltage
0x22	HW_ERR_VREF	Voltage out of range	-100 %LFL	Contact support.
0x23	HW_ENV_XCD_RANGE	Environmental (Temp., Press., Humid.) out of range	Normal	Return sensor to specified operating range. See Section 5.

Fault	Fault Message	Explanation	%LFL Output	User action
0x24	HW_ENV_SNSR_MALFUNCTION	Environmental sensor malfunction	-100 %LFL	Occurrence of this error will latch the sensor in this condition and no longer allow normal operation. Contact support.
0x25	HW_ERR_MCU_FLASH	Microcontroller error	-100 %LFL	Contact support.
0x26	HW_SENSOR_INITIALIZATION	Sensor in initialization mode (10 cycles)	-100 %LFL	Wait 10 cycles (~20 sec) for sensor to initialize.
0x30	SENSOR_NEGATIVE	Sensor output <-15%LFL; accuracy affected if flammable gas initially detected while in this condition	Normal	Wait for sensor to return to zero. If message persists >10 minutes, contact support.
0x31	CONDENSATION_DETECTED	Condensation condition exists at sensor (out of specification)	Normal	Raise temperature and/or lower humidity. See Section 5.
0x32	HW_SENSOR_MALFUNCTION	Gas sensing element malfunction	-100 %LFL	Contact support.

2.1.3. Checksum Calculation

The algorithm for checksum calculation is that of 16-bit CRC CCITT with start byte 0xFFFF. Checksum is computed over the entire packet (header and payload). The checksum field in the header is initialized with zeros before computing checksum. If there is no payload, checksum is computed against the header only. The following sample C code can be used to calculate the checksum for a buffer of a given size:

```
#include <stdlib.h>
#include <stdint.h>

static uint16_t crc_table[256] = {
    0x0000, 0x1021, 0x2042, 0x3063, 0x4084, 0x50a5, 0x60c6, 0x70e7,
    0x8108, 0x9129, 0xa14a, 0xb16b, 0xc18c, 0xd1ad, 0xe1ce, 0xf1ef,
    0x1231, 0x0210, 0x3273, 0x2252, 0x52b5, 0x4294, 0x72f7, 0x62d6,
    0x9339, 0x8318, 0xb37b, 0xa35a, 0xd3bd, 0xc39c, 0xf3ff, 0xe3de,
    0x2462, 0x3443, 0x0420, 0x1401, 0x64e6, 0x74c7, 0x44a4, 0x5485,
    0xa56a, 0xb54b, 0x8528, 0x9509, 0xe5ee, 0xf5cf, 0xc5ac, 0xd58d,
    0x3653, 0x2672, 0x1611, 0x0630, 0x76d7, 0x66f6, 0x5695, 0x46b4,
    0xb75b, 0xa77a, 0x9719, 0x8738, 0xf7df, 0xe7fe, 0xd79d, 0xc7bc,
    0x48c4, 0x58e5, 0x6886, 0x78a7, 0x0840, 0x1861, 0x2802, 0x3823,
    0xc9cc, 0xd9ed, 0xe98e, 0xf9af, 0x8948, 0x9969, 0xa90a, 0xb92b,
    0x5af5, 0x4ad4, 0x7ab7, 0x6a96, 0x1a71, 0x0a50, 0x3a33, 0x2a12,
    0xdbfd, 0xcbdc, 0xfbbf, 0xeb9e, 0x9b79, 0x8b58, 0xbb3b, 0xab1a,
```



```

0x6ca6, 0x7c87, 0x4ce4, 0x5cc5, 0x2c22, 0x3c03, 0x0c60, 0x1c41,
0xedae, 0xfd8f, 0xcdec, 0xddcd, 0xad2a, 0xbd0b, 0x8d68, 0x9d49,
0x7e97, 0x6eb6, 0x5ed5, 0x4ef4, 0x3e13, 0x2e32, 0x1e51, 0x0e70,
0xff9f, 0xefbe, 0xdfdd, 0xcffc, 0xbf1b, 0xaf3a, 0x9f59, 0x8f78,
0x9188, 0x81a9, 0xb1ca, 0xa1eb, 0xd10c, 0xc12d, 0xf14e, 0xe16f,
0x1080, 0x00a1, 0x30c2, 0x20e3, 0x5004, 0x4025, 0x7046, 0x6067,
0x83b9, 0x9398, 0xa3fb, 0xb3da, 0xc33d, 0xd31c, 0xe37f, 0xf35e,
0x02b1, 0x1290, 0x22f3, 0x32d2, 0x4235, 0x5214, 0x6277, 0x7256,
0xb5ea, 0xa5cb, 0x95a8, 0x8589, 0xf56e, 0xe54f, 0xd52c, 0xc50d,
0x34e2, 0x24c3, 0x14a0, 0x0481, 0x7466, 0x6447, 0x5424, 0x4405,
0xa7db, 0xb7fa, 0x8799, 0x97b8, 0xe75f, 0xf77e, 0xc71d, 0xd73c,
0x26d3, 0x36f2, 0x0691, 0x16b0, 0x6657, 0x7676, 0x4615, 0x5634,
0xd94c, 0xc96d, 0xf90e, 0xe92f, 0x99c8, 0x89e9, 0xb98a, 0xa9ab,
0x5844, 0x4865, 0x7806, 0x6827, 0x18c0, 0x08e1, 0x3882, 0x28a3,
0xcb7d, 0xdb5c, 0xeb3f, 0xfb1e, 0x8bf9, 0x9bd8, 0xabbb, 0xbb9a,
0x4a75, 0x5a54, 0x6a37, 0x7a16, 0x0af1, 0x1ad0, 0x2ab3, 0x3a92,
0xfd2e, 0xed0f, 0xdd6c, 0xcd4d, 0xbdaa, 0xad8b, 0x9de8, 0x8dc9,
0x7c26, 0x6c07, 0x5c64, 0x4c45, 0x3ca2, 0x2c83, 0x1ce0, 0x0cc1,
0xef1f, 0xff3e, 0xcf5d, 0xdf7c, 0xaf9b, 0xbfba, 0x8fd9, 0x9ff8,
0x6e17, 0x7e36, 0x4e55, 0x5e74, 0x2e93, 0x3eb2, 0x0ed1, 0x1ef0,
};

uint16_t crc_generate(uint8_t *buffer, size_t length, uint16_t startValue)
{
    uint16_t crc;
    uint8_t *p;
    int ii;

    crc = startValue;

    for(p = buffer, ii = 0; ii < length; ii++) {
        crc = (crc << 8) ^ crc_table[(crc >> 8) ^ *p];
        p++;
    }

    return crc;
}

```

For more information on how to use the above function, please look at the sample test program “Sample Code” located here: <https://nevedanano.com/downloads>

2.1.4. Startup and Measurement Sequence

Figure 3 describes the recommended steps after powering on the sensor plus the measurement sequence for getting answer data. The major steps consist of the following:

- After powering on the sensor, wait for the sensor to boot up completely (~3 seconds).
- Verify communication channel by asking the sensor for version information.
 - Protocol version can be used to determine available commands, answers or new data.
- Start measurement in “continuous” mode.
- Wait 2 seconds for the first measurement to complete.

- Get Answer.
- Repeat process to get answer at desired frequency.

The sensor initializes for the first 10 cycles after powering up. During this period, the sensor output is set to “-100 %LFL”, the sensor status is set to HW_SENSOR_INITIALIZATION (0x26), and the sensor is not capable of reporting gas concentrations. Once initialization is complete, the sensor is ready to report gas concentrations, and the status is set to 0x00.

Note: It takes approximately 2 seconds to calculate and complete a measurement. If multiple requests to read the Answer register (0x01) were made within a two-second window, one might get the same answer. This depends on whether a new measurement is calculated between multiple Answer requests. The MPS Cycle Count (“COUNT”) in the Answer Response is incremented after each measurement is calculated. Therefore, when processing an “answer,” one should compare the COUNT value in the answer against the COUNT value from the previous answer. If the COUNT value did not increment, this is a repeated answer. If the COUNT value incremented, this is a new answer from the latest measurement cycle. When continuous measurement is stopped and restarted, the COUNT value resets to 1 with the first measurement.

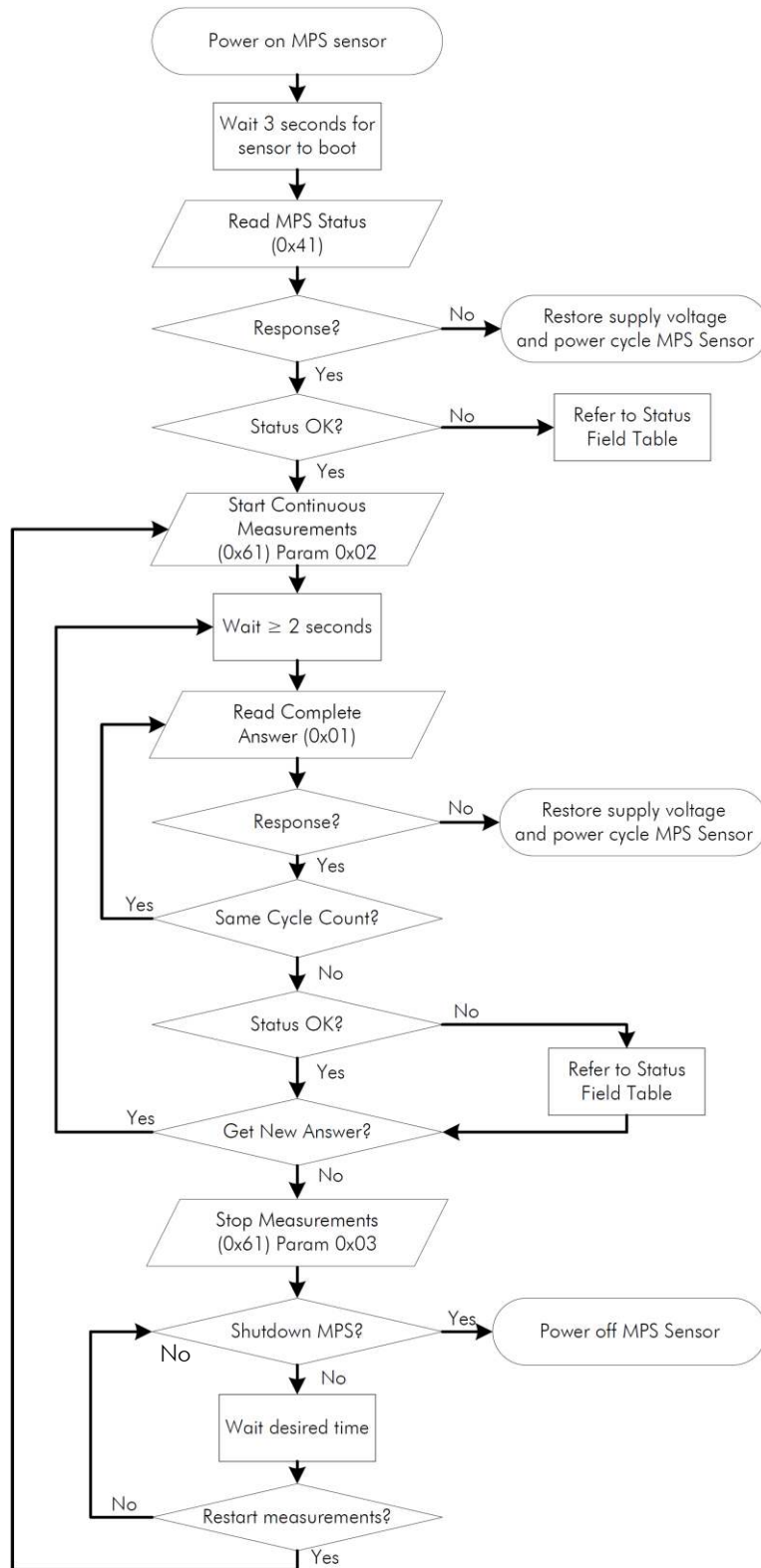
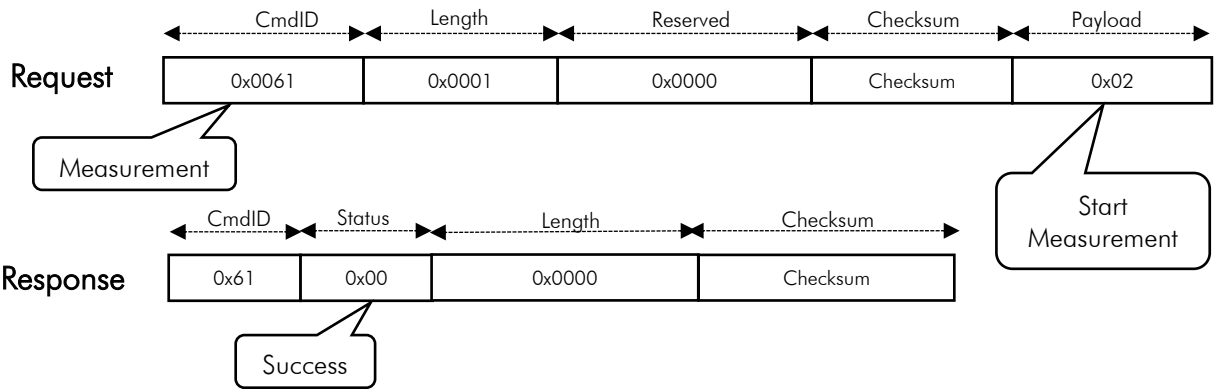

Figure 3: Startup and Measurement Sequence

Figure 4 describes sample Request and Response packets for the Perform Measurement and Get Answer Vector sequences.

Perform Measurement



Get Answer Vector

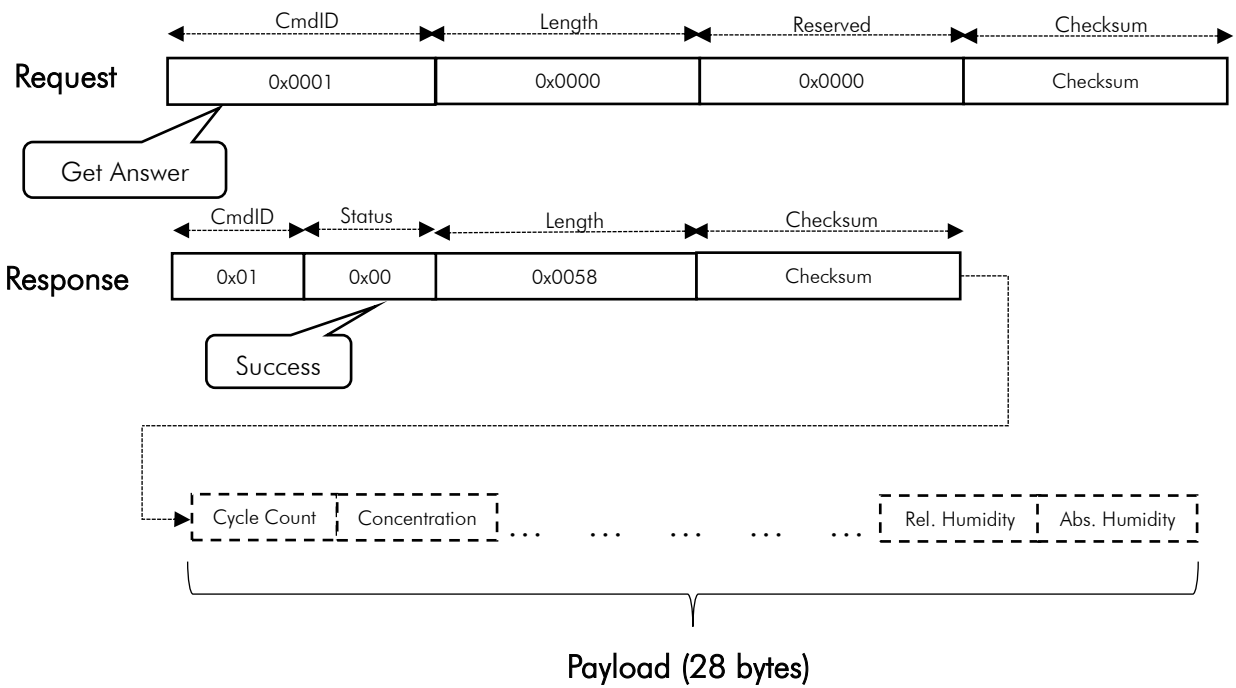

Figure 4: Sample Request and Response Packets for Performing Measurement and Get Answer Vector

2.1.5. Command Table

Table 1: UART commands with calculated checksum

Hex Code	Command ID	Payload Length [bytes]		Request Packet (Little-Endian Format)				
		Request	Response	CmdID	Length	Reserved	Calculated Checksum*	Payload
0x01	ANSWER	0	28	0x01 0x00	0x00 0x00	0x00 0x00	0xed 0x76	null
0x03	CONC	0	4	0x03 0x00	0x00 0x00	0x00 0x00	0x4b 0xf9	null
0x04	ID	0	4	0x04 0x00	0x00 0x00	0x00 0x00	0x53 0x3e	null
0x21	TEMP	0	4	0x21 0x00	0x00 0x00	0x00 0x00	0x85 0x0d	null
0x22	PRES	0	4	0x22 0x00	0x00 0x00	0x00 0x00	0xf0 0xc5	null
0x23	REL_HUM	0	4	0x23 0x00	0x00 0x00	0x00 0x00	0x23 0x82	null
0x24	ABS_HUM	0	4	0x24 0x00	0x00 0x00	0x00 0x00	0x3b 0x45	null
0x41	STATUS	0	1	0x41 0x00	0x00 0x00	0x00 0x00	0x3d 0x80	null
0x42	VERSION	0	8	0x42 0x00	0x00 0x00	0x00 0x00	0x48 0x48	null
0x43	SENSOR_INFO	0	100	0x43 0x00	0x00 0x00	0x00 0x00	0x9b 0x0f	null
0x61	MEAS	1	0	0x61 0x00	0x01 0x00	0x00 0x00	0x57 0x93	0x02
0x61	MEAS	1	0	0x61 0x00	0x01 0x00	0x00 0x00	0x35 0xb7	0x22
0x61	MEAS	1	0	0x61 0x00	0x01 0x00	0x00 0x00	0x76 0x83	0x03
0x62	RESET	0	0	0x62 0x00	0x00 0x00	0x00 0x00	0x20 0x33	null

2.1.6. Command Descriptions

1. Command 0x01 – ANSWER – Read Complete Answer

Description: Returns a complete answer in one read operation.

Parameters: N/A

Response:

CYCLE_COUNT	32-bit unsigned value. Cycle Number of this measurement (incremented after each measurement)
CONC	32-bit floating point value. Flammable gas concentration [%LFL]
ID	32-bit unsigned value. Flammable gas ID. See “Command 0x04 – ID” for descriptions of gas ID values.
TEMP	32-bit floating point value. Ambient temperature [°C]
PRESSURE	32-bit floating point value. Ambient pressure [kPa]
REL_HUM	32-bit floating point value. Ambient relative humidity [%RH]
ABS_HUM	32-bit floating point value. Ambient absolute humidity [$\frac{g}{m^3}$]

2. Command 0x03 – CONC – Read Flammable Gas Concentration

Description: Returns flammable gas concentration (%LFL) as measured by the MPS.

Parameters: N/A

Response: CONC 32-bit floating point value. Flammable gas concentration (%LFL)

3. Command 0x04 – ID – Read Flammable Gas ID

Description: Returns flammable gas ID as determined by the MPS.

Parameters: N/A

Response: ID 32-bit unsigned value. Flammable gas ID.

ID	Description
0	No Gas
7	Refrigerant
253	Unknown Gas
254	Under Range – Concentration less than 0 %LFL
255	Over Range – Concentration greater than 100 %LFL

4. Command 0x21 – TEMP – Read Temperature

Description: Returns the ambient temperature (°C) as reported by the integrated environmental sensor.

Parameters: N/A

Response: TEMP; 32-bit floating point value. Ambient temperature (°C).

5. Command 0x22 – PRES – Read Pressure

Description: Returns the ambient pressure (kPa) as reported by the integrated environmental sensor.

Parameters: N/A

Response: PRESSURE; 32-bit floating point value. Ambient pressure (kPa).

6. Command 0x23 – REL_HUM – Read Relative Humidity

Description: Returns the ambient relative humidity (%RH) as reported by the integrated environmental sensor.

Parameters: N/A

Response: REL_HUM 32-bit floating point value. Ambient relative humidity (%RH).

7. Command 0x24 – ABS_HUM – Read Absolute Humidity

Description: Returns the ambient absolute humidity ($\frac{g}{m^3}$) as calculated by the MPS.

Parameters: N/A

Response: ABS_HUM32-bit floating point value. Ambient absolute humidity ($\frac{g}{m^3}$).

8. Command 0x41 – STATUS – Read MPS Status

Description: Returns the status of the MPS; refer to Sec. 2.1.2 for status descriptions.

Parameters: N/A

Response: STATUS 8-bit unsigned value. Status of MPS

9. Command 0x42 – VERSION – Read MPS Version Info

Description: Returns the software, hardware and protocol versions of the MPS.

Parameters: N/A

Response: SW_VERSION 8-bit unsigned values. Version is W.X.Y.Z

HW_VERSION 8-bit unsigned values. Version is W.X

PROTOCOL_VERSION 8-bit unsigned values. Version is W.X

MPS Version Info																															
1	2	3	4	5	6	7	8	9	10	11	12	13	14	15	16	17	18	19	20	21	22	23	24	25	26	27	28	29	30	31	32
SW Version W [7:0]								SW Version X [7:0]								SW Version Y [7:0]								SW Version Z [7:0]							
33	34	35	36	37	38	39	40	41	42	43	44	45	46	47	48	49	50	51	52	53	54	55	56	57	58	59	60	61	62	63	64
HW Version W [7:0]								HW Version X [7:0]								Protocol Version W [7:0]								Protocol Version X [7:0]							

10. Command 0x43 – SENSOR_INFO – Read MPS Sensor Info

Description: Returns information about the sensor.

Parameters: N/A

Response: SERIAL_NUM Sensor serial number. 32 bytes, zero-padded ASCII string.

SENSOR_TYPE Sensor type. 32-bit unsigned integer. (Note: “MPS A2L Refrigerant Gas Sensor” sensor type = 0x04)

SENSOR_SKU SKU assigned to the sensor. 32 bytes, zero-padded ASCII string.

CAL_DATE Date of last calibration. 16 bytes, zero-padded ASCII string. Format is MM/DD/YYYY.

MFG_DATE Date of manufacture. 16 bytes, zero-padded ASCII string. Format is MM/DD/YYYY.

11. Command 0x61 – MEAS – Perform Measurement

Description: Sets the sensing mode (idle, single, or continuous) and “concentration unit” in the measurement.

Parameters: The parameter to the Measurement command is 1 byte in length but consists of two, 4-bit values: Concentration Unit (bits 7:4) and Mode (bits 3:0).

Measurement Value (Byte)	
Conc. Unit [7:4]	Mode [3:0]

The “concentration unit” (bits 7:4 of the measurement byte) is %LFL; this is the unit that will be reported for commands 0x01 and 0x03.

Unit	Name	Description
0x0	PERCENT_LFL	Concentration reported as %LFL.

The measurement mode (bits 3:0 of the measurement byte) consists of the following possible values:

MODE	Name	Description
0x2	MPS_CONT	MPS operates in an autonomous, continuous mode
0x3	MPS_STOP	Stop measurement – no measurements are being taken

Response: N/A

12. Command 0x62 – RESET– Reset MPS

Description: Perform a soft reset of the MPS, clearing all data and states.

Parameters: N/A

Response: N/A

2.2. Sensor Analog Output Mode

The MPS A2L Refrigerant Gas Sensor is factory-configurable to report gas concentrations via an analog signal that mimics the output of conventional catalytic bead flammable gas sensors. By default, this feature is disabled. The analog output signal from the MPS A2L Refrigerant Gas Sensor is generated with a digital-to-analog converter. The standard analog output range, shown in Fig. 5, is 0.4 V (0 %LFL) to 2.0 V (100 %LFL), linearly increasing at $0.016 \frac{V}{\%LFL}$. As with the digital communication mode, the MPS output concentration resolution is 0.1 %LFL for analog outputs. Upon startup, the analog output pin may report between 0.75-1.75 V momentarily (<100 ms) during initialization.

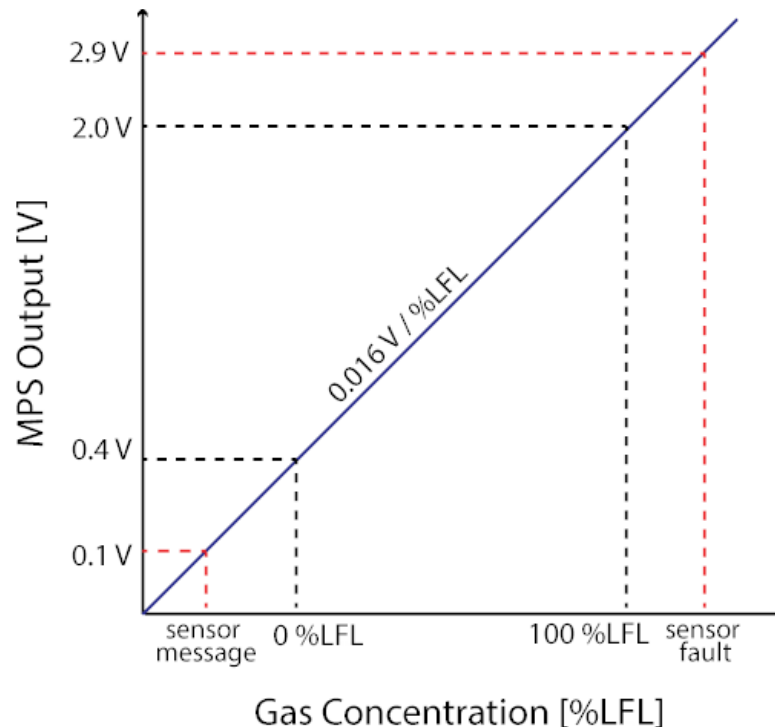

Figure 5: MPS A2L Refrigerant Gas Sensor output when configured in analog mode

When there is an error condition or special status, as reported by the sensor status field (outlined in Section 2.1.2.), the voltage level does not indicate gas concentration. Instead, the voltage is set to report an error or special status (see table below). Only critical statuses and messages that indicate the sensor's initialization sequence are conveyed to the user. The following table indicates the output voltage corresponding to each sensor message and critical status.

Status	Voltage [V]
HW_ERR_AO	2.9
HW_ERR_VREF	2.9
HW_ENV_SNSR_MALFUNCTION	2.9

HW_ERR_MCU_FLASH	2.9
HW_SENSOR_INITIALIZATION	0.1
HW_SENSOR_MALFUNCTION	2.9

Non-critical status messages (e.g.: [0x23] HW_ENV_XCD_RANGE, [0x31] CONDENSATION_DETECTED) are not reported via the analog output. Alternate analog output configurations are available with outputs between 0.04 and 2.4V and a configurable sensitivity slope, including rising or falling volts/%LFL. Contact NevadaNano for details.

2.2.1. Analog Out Electrical Integration

Figure 6 describes a simple schematic of the analog output stage of the sensor connected to an external system to measure the analog out voltage.

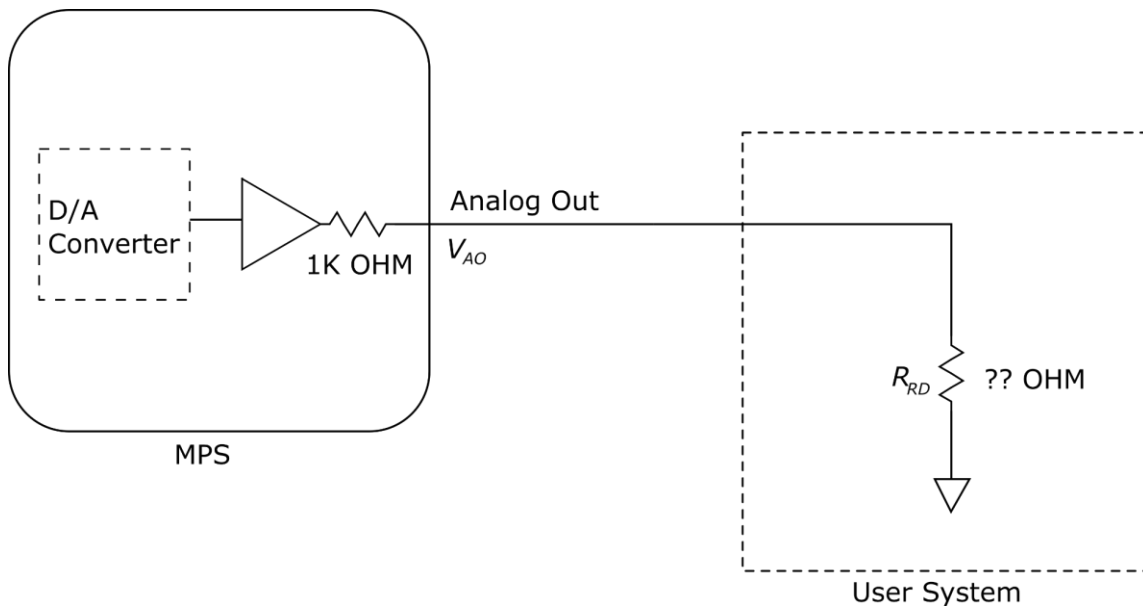

Figure 6. Analog output stage of the MPS coupled to a user system

The internal, 1-kOhm resistor within the sensor, in series with the load resistance of the user's voltage reading equipment (VRE), creates an attenuator. This attenuator reduces the voltage at the input of the VRE, according to the following formula:

$$V_{RD} = V_{AO} \left(\frac{R_{RD}}{R_{RD} + 1,000\Omega} \right)$$

Where:

V_{RD} = Voltage into the VRE

V_{AO} = Voltage out of the MPS analog out pin

R_{RD} = Resistance of the input of the VRE

1000 Ω = the output resistance of the MPS analog out

For example, as shown in Figure 7, a VRE internal resistance load (R_{RD}) of 50 k Ω will result in a 2% attenuation in the voltage and therefore a 2% attenuation in %LFL reading. System designers should account for this when implementing systems using the analog out signal from the sensor with a low-input-resistance VRE.

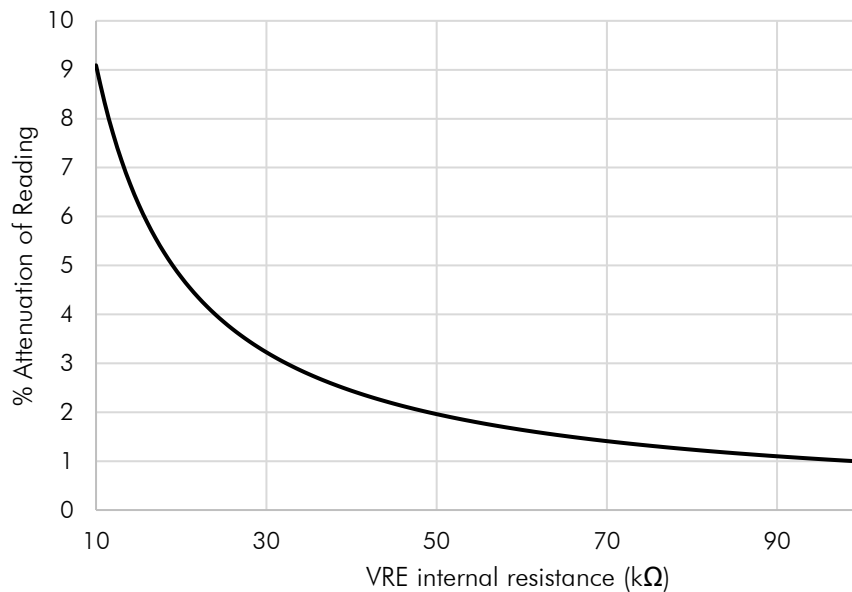

Figure 7: Voltage reading attenuation as a function of coupled system’s internal resistance

2.2.2. Using Analog Output and UART with Auto Start

There are three configurations of MPS sensor that report concentration using an analog voltage: (1) analog output with UART; (2) analog output with auto start; and, (3) analog output with auto start and UART. An MPS sensor configured with both analog out and UART is started manually using either the UART API or the MPS Gas Sensor Interface software. A sensor configured with auto start will begin its startup sequence as soon as power is applied to the sensor. This includes the situation where power is momentarily interrupted.

When configured with both auto start and UART, the sensor will respond to API commands sent over UART as soon as power is applied. Viewing auto-started sensor output using the MPS Gas Sensor Interface software will always require restarting the sensor; the “start” button that initiates the display of sensor information in the Interface Software is hardwired to send a restart command to the sensor.

2.3. Testing the MPS A2L Refrigerant Gas Sensor

The MPS determines the presence and quantity of A2L refrigerant by differentiating the molecular properties of the analyte gas from the ambient gas in which the sensor is started. The MPS is optimized to operate in “real world” conditions. When testing the MPS in a laboratory environment, it is important to not introduce unrealistic, artificial conditions that can confuse the computed result. In particular, it is important that care is taken to ensure that the ambient gas composition remains consistent throughout testing.

A common testing error occurs when the MPS is started in atmospheric air, then exposed to an A2L gas that has been diluted with synthetic “zero air.” In this case, the MPS will compute a result based on the addition of A2L and the subtraction of argon, carbon dioxide and other trace gases in the atmosphere. In that particular case, the computed concentration would be inaccurate.

Figure 8 below depicts both correct and incorrect testing scenarios involving the use of zero air.

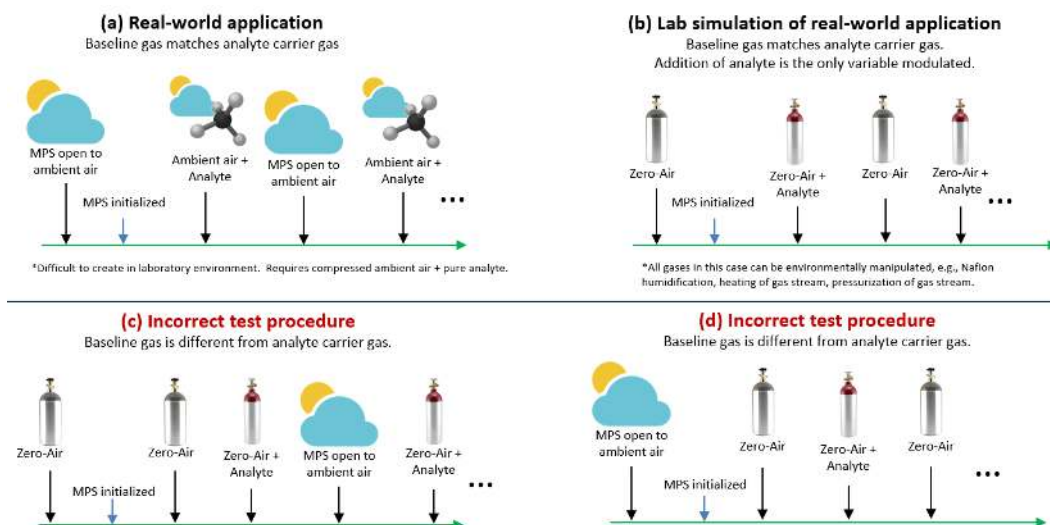

Figure 8: (a) The real-world A2L gas leak scenario. (b) The method for simulating the real-world scenario in a laboratory. Incorrect test procedures are shown in (c) and (d); in these cases, the carrier-only condition does not use the same “air” as the carrier + flammable gas condition, causing inaccurate results.

A “best practice” for performance testing in a laboratory is to use a humidified zero air background, followed by a switch to a humidified analyte stream with the same zero air composition as balance gas, then a switch back to humidified zero air to clear the test chamber. This mimics real-world MPS performance, where A2L gas is introduced into relatively invariant ambient air. Note that the MPS compensates for changes in environmental conditions.

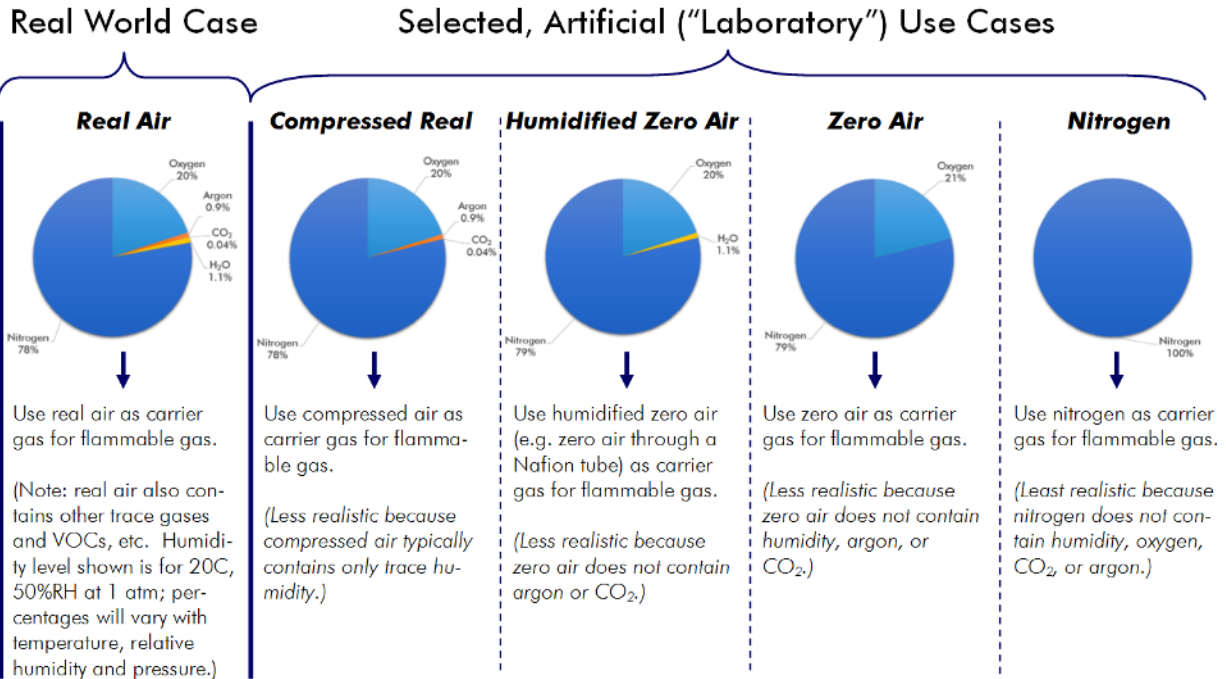

Figure 9: Various "air" options for use as the carrier, or background, gas during A2L gas testing. The best practice is to use one of the options toward the left side of the figure. In addition, do not switch between two different types of "air" during an experiment, as this can produce unwanted (and unrealistic) testing artifacts.

2.4. Setup #1: Testing in a Tank

The test setup shown in Figure 10 requires minimal equipment. A single gas cylinder of refrigerant gas is plumbed through a regulator, then a rotameter with a hand-turn valve (or an automated mass flow controller) for modulating flow rate. Humidity-permeable tubing (e.g. Nafion™ TT-110¹) can be used in-line to humidify the gas stream to the ambient humidity level. The gas is then plumbed into an enclosed volume such as a glass or plastic tank (or the plenum of an HVAC system) containing the sensors. A small fan can be included inside the tank to ensure rapid mixing. A typical test entails operating the sensors in the ambient air inside the control volume, then routing refrigerant gas into the test volume just like a flammable refrigerant gas leak.

As an example, a tank measuring 12 x 12 x 18 inches has a volume of 2,592 in³ (0.0425 m³). R-32 refrigerant reaches 100 %LFL at a concentration of 14.4% by volume in air. So, flowing pure R-32 refrigerant through the rotameter at 300 ml/min (18.3 in³/min) for 10.2 minutes will gradually increase the total volume of R-32 in the tank to 186 in³, which is 50 %LFL.

¹ <https://www.permapure.com/products/nafion-tubing/nafion-dryer-performance-and-selectivity/>

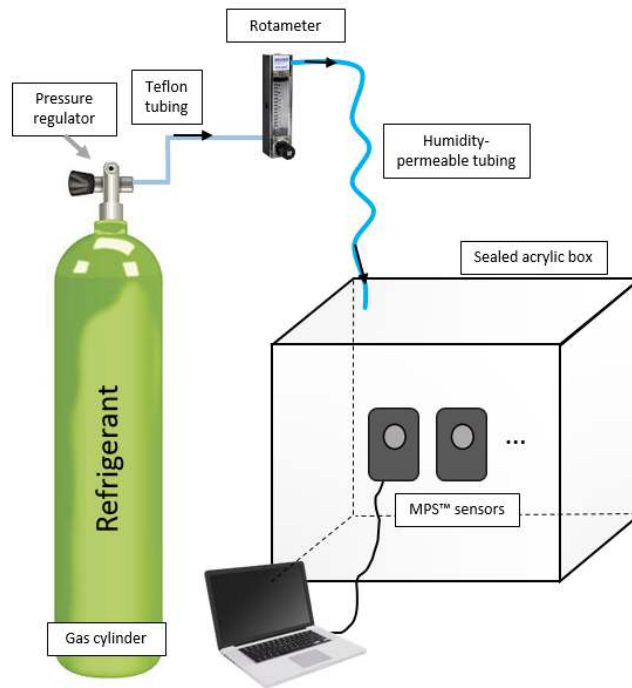

Figure 10: Setup #1--Testing in a Tank

2.5. Setup #2: Testing in Various Environmental Conditions

A test of sensor response in various environmental conditions can be conducted using the setup shown in Figure 11. Two regulated gas cylinders are used: one containing refrigerant, and the other containing compressed air.

Regulated gas cylinders are connected to a gas mixing system (e.g. Environics 4040) to control gas flow rates and concentrations. The gas travels through a heat exchanger and humidity-permeable tubing (e.g. Nafion™ TT-110), allowing the gas to reach the chamber temperature and relative humidity. Gas then flows serially through each of the MPS sensors and out a vent exhaust-tube. The environmental chamber is programmed with the required temperature/humidity profiles for each test. Gas profiles are created in the gas mixing system software to deliver the analyte at the correct time. Flow rate is constant at 300 mL/min for both analyte and air throughout the tests.

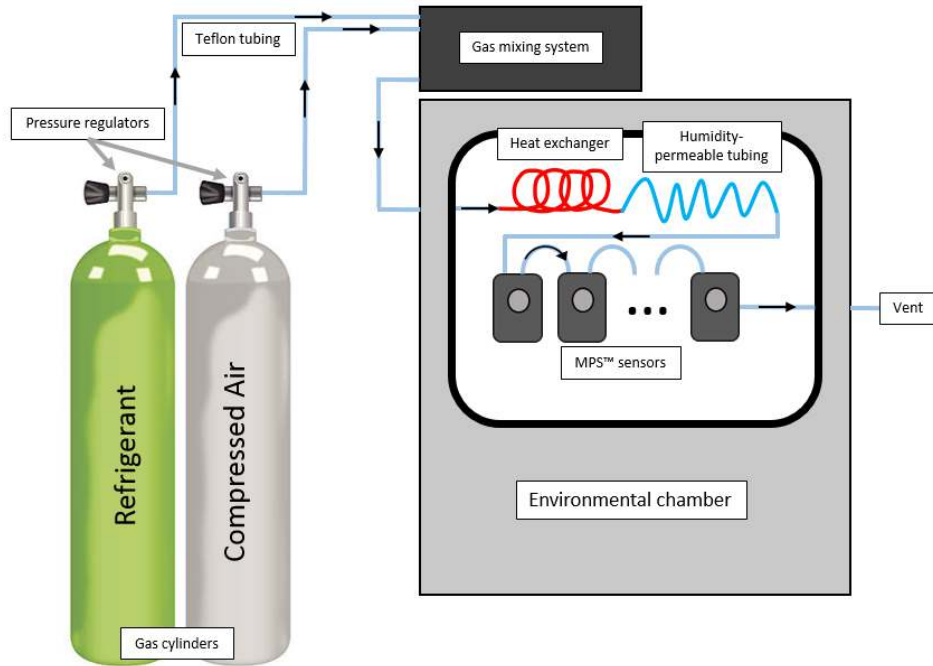

Figure 11: Setup #2: Testing in Various Environmental Conditions

3. Operating Conditions for the MPS A2L Refrigerant Gas Sensor

The table below provides a summary of standardized tests and test conditions to which the MPS A2L IS Industrial form factor Refrigerant Gas Sensor has been subjected; similar performance can be expected for the Mini Standard form factor. The IS sensor has passed all of these tests by demonstrating normal flammable gas detection performance both before and after each test.

Test	Specification	Summary of Test Conditions
Low Temperature Operating	IEC 60068-2-1	500 Hours @ -50°C
High Temperature Operating	IEC 60068-2-2	1000 Hours @ 85°C
Vibration	IEC 60068-2-6	31Hz – 150 Hz (2G acceleration), 1 hour per axis, 3 axes
Shock	IEC 60068-2-27	50G peak/11ms half sine pulse, 3 axes (positive and negative pulses)
Drop	IEC 60068-2-31	1-meter drop onto concrete
Damp heat - steady state	IEC 60068-2-78	500 hours @ 40°C/93% RH
Temperature cycling	JESD22-A104E	From -40°C to 85°C for 200 cycles
Sand/Dust	MIL-STD-810G Method 510.5	Sand: 150-850 μm SiO ₂ particle size, 23 m/s nom. velocity, 1.5 hrs @ 70°C per axis, 3 axes Dust: Red China Clay, 1.5 m/s nom. velocity, 6 hrs @ 20°C and 6 hrs @ 70°C
Poisoning	NevadaNano	1,200 ppm-hours H ₂ S (50 ppm for 24 hours) 10,400 ppm-hours siloxanes (Decamethylcyclopentasiloxane) (100 ppm for 4 hours, then 1,000 ppm for 10 hours) 0.25 ppm-hours NO ₂ (3 ppm for 5 minutes) 0.83 ppm-hours HCN (10 ppm for 5 minutes) 0.75 ppm-hours SO ₂ (9 ppm for 5 minutes) 0.17 ppm-hours Cl ₂ (2 ppm for 5 minutes) 4.17 ppm-hours NH ₃ (50 ppm for 5 minutes)
Electrostatic Discharge	JEDEC JS001-2017	Human Body Model, passed at 2 kV
EMC: Radiated Emissions	EN 55011	30 MHz to 1 GHz
EMC: RF Electromagnetic Field Immunity	IEC/EN 61000-4-3	80 MHz to 6 GHz at 10 V/m
EMC: Magnetic Immunity	IEC/EN 61000-4-8	30 A/m, 3 axes, 50 Hz and 60 Hz

3.1. Response to Other Gases

3.1.1. Carbon Dioxide (CO₂)

Carbon dioxide is a component of normal air at concentrations near 400 ppm. This ambient amount of CO₂ is already taken into account by sensor calibrations. The MPS is unaffected by elevated CO₂ concentrations up to approximately 0.65% by volume (6,500 ppm); concentrations above this can be misinterpreted by the sensor as refrigerant gas. The sensor is immune to poisoning by CO₂.

Note: Exhaled human breath contains CO₂ at concentrations of approximately 40,000 ppm. During respiration, the CO₂ replaces oxygen, reducing its concentration from 20.95% by volume in normal air to 13.6-16% in exhaled air. **As such, breathing directly onto the sensor can cause it to falsely report refrigerant gas for a brief period.**

3.2. Hazardous Locations and System Integration

Integrating the MPS into intrinsically safe systems requires additional design consideration. Refer to the MPS Hazardous Locations User Guide (<https://nevadanano.com/downloads>) for information regarding certifications, protection concepts, entity parameters, etc. Note: The MPS A2L Refrigerant Gas Sensor is only hazloc certified in the IS form factor. As such, the Mini form factor is not intended for applications requiring intrinsic safety.

4. Environmental Faults and Conditions Affecting Accuracy

The MPS A2L Refrigerant Gas Sensor is specified to operate in the following conditions: -40 to 75 °C, 0 to 100 %RH; and 80 to 120 kPa. The MPS will fail safe and permanently latch to a non-functional state if exposed to extreme excursions (e.g. liquid water inside sensor, or temperatures > 85 °C for more than 10 seconds) of specified environmental specifications. The sensor has built-in self-test capabilities to detect and report excursions outside these regimes:

- Fault 0x23, HW_ENV_XCD_RANGE -- Environmental (Temp., Press., Humid.) out of range
- Status 0x24, HW_ENV_SNSR_MALFUNCTION – Environmental (Temp., Press., Humid.) extremely out of range. Sensor permanently latches.
- Fault 0x31, CONDENSE_COND -- Condensation condition exists at sensor

The sensor is capable of operating outside of these regimes, as well as during abnormally rapid environmental fluctuations. The impact on sensor performance and output in these conditions is summarized in the following table:

Condition	Fault reported	Impact on sensor performance and output
Sensor environment out of range	0x23 - HW_ENV_XCD_RANGE	The sensor will still detect and report refrigerant gas, though output accuracy can be diminished while the condition persists.
Condensation condition at sensor	0x31 - CONDENSE_COND	The sensor will still detect and report refrigerant gas, though output accuracy can be diminished while the condition persists and for one minute afterward.
Rapid humidity changes	None	If the sensor is already reporting refrigerant gas, no adjustments are made to sensor output. If gas is not being detected, the sensor may enhance its drift compensation during periods of rapid humidity change (> 0.5% RH/sec). The sensor will still detect and report refrigerant gas during these periods; however, accuracy may be slightly degraded.
Rapid temperature change	None	None

Sensor accuracy can also be diminished in certain cases of very slow gas accumulation (< 0.15% LEL per minute).

5. Electromechanical Integration

5.1. General Guidelines

The MPS Mini family of gas sensors is designed to be permanently mounted to a printed circuit board. The male header is Samtec P/N: TLW-105-06-G-S and the female connector is Samtec P/N: SLW-105-01-G-S. Both interconnects are readily available in distribution.

In addition to the electrical interconnects, the Mini package has two, plastic locating-features. These locating features can engage with a 1.10 mm to 1.50 mm dia hole on the PCB for more precise locating of the sensor relative to the plane of the PCB.

The IS pinout is indicated in Figure 15. The mating receptacles are available in distribution, and can be found using Mill-Max P/N: 0384-0-67-80-23-27-10-0.

Note: The Analog Out pin, if unused, must be left unterminated as an "open" or "no-connect" in the system integrator's PCB design.

In powering the MPS sensor, the following criteria need to be met:

- Voltage range must be 3.3-5.0 V \pm 5%
- Ripple and noise should not exceed 50 mV
- The supply must be capable of providing at least 35 mA without appreciable voltage drop
- The voltage rise rate at power up should be greater than 250 μ s per volt from a cold start (that is, when powering up a sensor that has been off for more than 5 seconds)

Achieving the proper voltage rise rate can be accomplished using voltage regulators with “soft-start” capability, though added capacitance (less preferred), or by placing a series resistor between the voltage source and the MPS power pin.

If the voltage rise rate condition above is not met when powering up a sensor that has been off for more than 5 seconds, a small percentage of sensors may power up into a state in which they do not respond to commands or do not generate the proper analog output. If this occurs, shutting power off to the sensor for between 0.5 to 2 seconds and then immediately powering the sensor back on will cause the sensor to recover and power up normally, *even if the voltage rise rate condition above is not met.*

5.2. A2L Mini Form Factor Critical Dimensions and Pinout

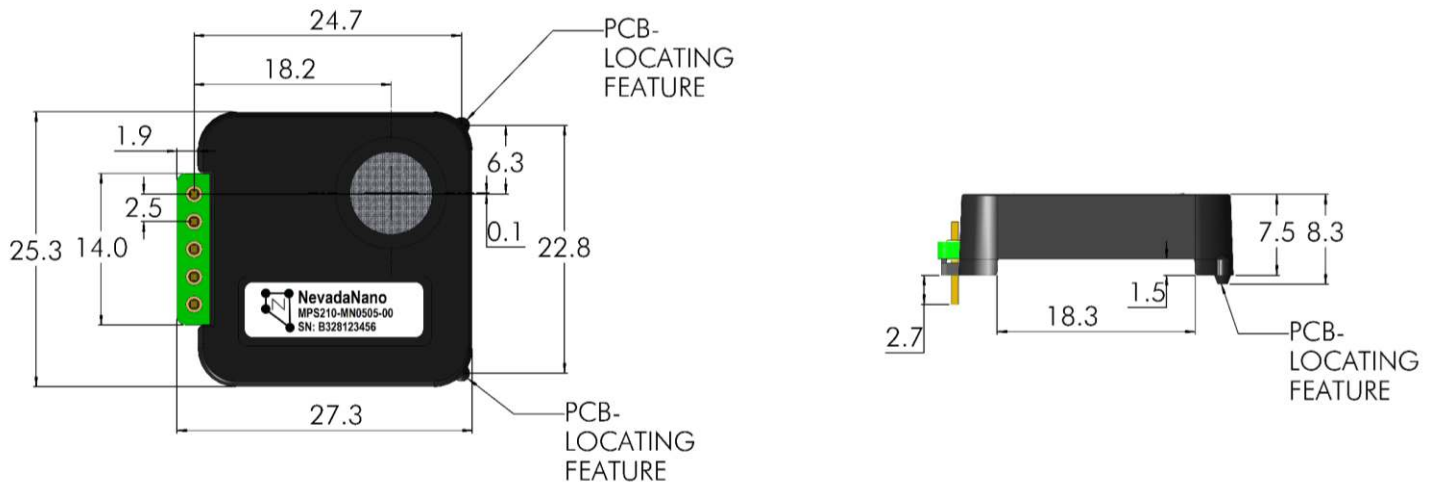

Figure 12: A2L Mini critical dimensions (mm)

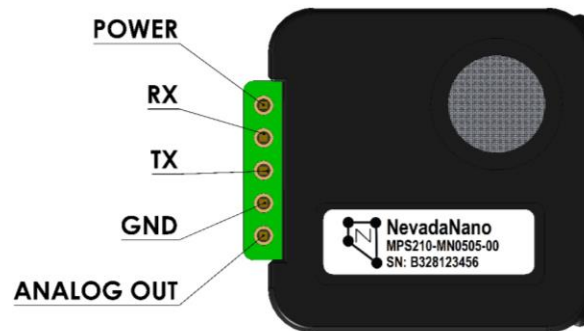

Figure 13: A2L Mini electrical pinout configuration

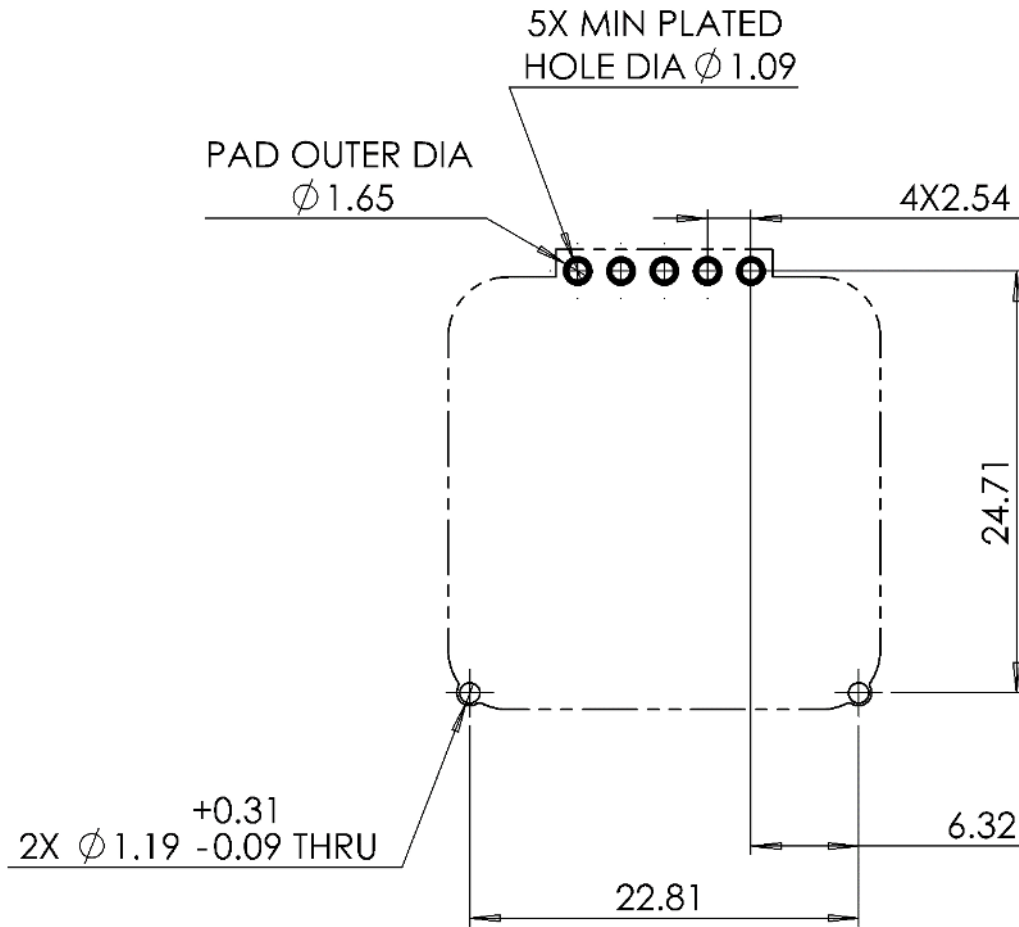

Figure 14 Recommended PCB Layout

5.3. A2L IS Form Factor Critical Dimensions and Pinout

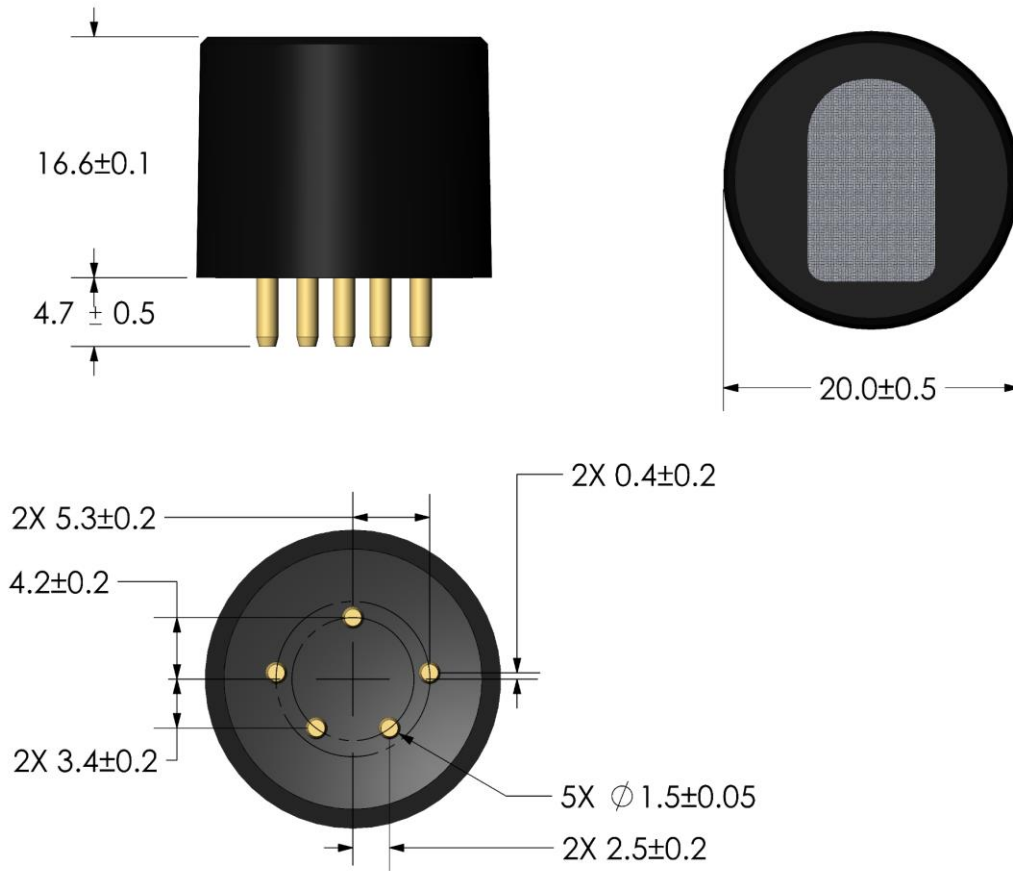

Figure 6: A2L IS critical dimensions (mm)

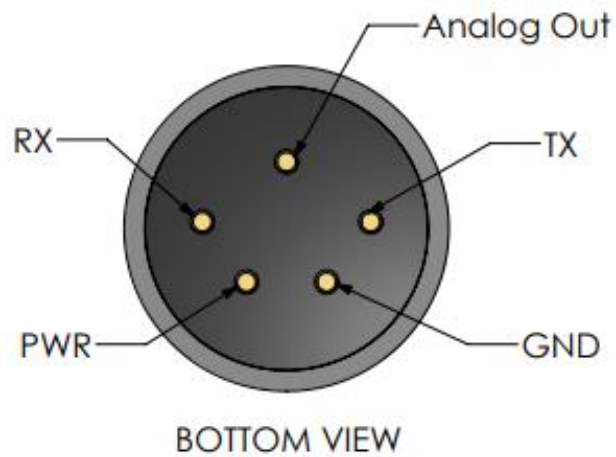

Figure 7: A2L IS electrical pin configuration

5.4. MPS Mini PCB Mounting Guidelines

5.4.1. Clearances from Heat-Generating Components

When designing the PCB layout to integrate the MPS Mini, consideration should be given to the location of any significant heat-generating components either adjacent to or under the sensor. All MPS sensor designs utilize an environmental monitoring system internal to the sensor to make accurate measurements of temperature, pressure, and humidity, and to compensate for these environmental effects. Components that raise the ambient temperature in the vicinity of the MPS—especially locally, where one portion of the Mini is heated more than other portions—could lead to inadequate environmental compensation and/or inaccurate gas reporting. Careful consideration should be given to avoid raising the ambient temperature in the vicinity of the MPS more than about 3°C.

5.4.2. Enclosure Opening to Sense the Presence of Gas

The goal when designing the opening in the application enclosure should be to allow the MPS Mini clear, unobstructed access to the external environment to be sensed and to not allow the buildup of “stale” air or gases of interest in the application enclosure, which could adversely affect the response of the MPS Mini sensor. The opening in the application enclosure to allow the MPS Mini sensor to detect gases should consider the following criteria:

- The opening in the application enclosure through which gases flow to the Mini should be no smaller than the opening in the top of the MPS Mini sensor.
- The MPS Mini sensor should be located as close to the external opening of the application enclosure as possible.
- The space between the MPS Mini sensor and the inner surface of the application enclosure should include a gasket sealing the area surrounding the opening in the MPS Mini sensor to prevent the buildup of “stale” air in the enclosure which could affect the response of the sensor.
- For specific integration design questions pertaining to adequate flow of gas to the Mini, contact NevadaNano for guidance.

5.4.3. Soldering the MPS Mini Sensor to a PCB

The following guidelines should be followed when soldering the MPS Mini sensor:

1. The plastic enclosure of the MPS Mini *CANNOT* withstand the heat developed in SMT reflow or wave solder operations. In addition, internal components of the sensor can be compromised during the extreme heat of these operations. NevadaNano will not warrant sensors that have been exposed to these processes.
2. The recommended attachment method is manual solder, either by hand soldering or robotic soldering. Use a no-clean flux type wire solder, such as Kester 268 series flux core wire solder (EX: 96-7069-9515) or equivalent.

3. Using the above referenced solder will require a soldering device temperature of between 371-400 °C (700-750 °F). The soldering operation should take no more than 10 seconds per pin.
4. Do not expose the PCB assembly to cleaning operations, using either water or chemical solvents after the MPS sensor has been attached. High-pressure spray from these operations can cause ingress into the MPS sensor opening and damage the sensor.



Nevada Nanotech Systems Inc.
1395 Greg Street, Suite 102
Sparks, Nevada 89431
United States
Tel: +1 775 972 8943
Fax: +1 775 972 8078
info@nevanano.com
www.nevanano.com