



## **4-20mA CYBER<sup>®</sup>**

*Cyber<sup>®</sup> Transmitter for flammable, toxic and IR gas detection*  
*Cyber<sup>®</sup> Head Increased security in ATEX certified head*

NET  
DRAFT version 2.1 - 2008





## 1. Introduction

---

The *4-20mA Cyber® transmitter* is a microprocessor based product, designed for gas sensing applications. It may be used for the detection of toxic gases, using electrochemical cells and for flammable gases, using catalytic gas sensors.

The raw signal input from the sensor is processed by the microprocessor, which also stores sensor's information.

The readout data is available both in analogue and digital format.

Information such as alarm thresholds, fault conditions, calibration data etc are available in the microprocessor's registries.

The *4-20mA Cyber® transmitter* version is a complete transmitter, designed to provide the standard industrial 4-20mA output and serial line RS485. This device was designed for industrial applications. It should be accommodated in an appropriate case, provided with connection facilities and basically is ready to be used.

The main features of the 4-20mA Cyber are as follows:

- powered at +12V or +24V
- standard 4-20mA output
- RS485 serial communication
- Fault and Alarm thresholds TTL programmable outputs,
- external LED output.
- 5V power supply output for other devices (ex.: calibration keypad)

## 2. Operation

---

### *General description*

The *4-20mA Cyber® transmitter* device consists of three boards overlapped. The first board is particular for each sensor technology, one for catalytic sensors, another for electrochemical sensors and a third version for the IR sensor IRIS Pro.

The second and the third boards are common for all versions, containing the microprocessor, the power supply and the standard outputs in 4-20mA and RS485.

### *Versions*

The version designed for the catalytic sensors will be used for the detection of flammable gases. The whole range of Nemoto catalytic single header and twin sensors may be fitted on this board.

The resulting device will monitor a flammable gas in the range 0-100%LEL.

The version designed to accommodate the electrochemical cells, may fit both the Nemoto electrochemical cells and 7 series like cells, for gases for which Nemoto doesn't cover the detection.

The resulting device will be able to monitor a wide range of toxic gases as well as oxygen. The detection range depends on the sensor fitted. The standard applications cover:

- CO detection range 0-300ppm
- H2S detection range 0-100ppm
- NH3 detection range 0-100ppm
- NO2 detection range 0-20ppm

- O2 detection range 0-25%v/v

Optionally, the whole block of electronics with the fitted sensor may be accommodated in an ATEX approved stainless steel head. This is the *Cyber*<sup>®</sup> *Head* device, which features an option for electrochemical cells and for the IR sensor in Intrinsically Safe protection mode.

The device will be powered at 12V or 24V, making sure that the power supply is between 10V and 30V.



⚡ **WARNING** ⚡ Only for IS version: The interfacing device must guarantee that in case of a critical fault, expected or unexpected, the maximum power supply voltage on all connecting wires of the *Cyber*<sup>®</sup> *Head* device NEVER exceeds 30 Vcc.

---

A number of versions of the device are available, depending on the gas sensor mounted.

The various options are presented in the drawings of Chapter 6 - Mechanical specifications.

As signal output there are featured two options:

- Standard 4-20mA current source type,
- Standard RS485 serial line featuring a digital communication in standard ModBUS

#### *Analogue current 4-20mA output*

The *4-20mA Cyber*<sup>®</sup> *transmitter* features a standard industrial 4-20mA output in source current version. The output is calibrated so that the readout is 4mA at zero gas and 20mA at full scale.

#### *RS485 serial line*

The serial communication output is a standard industrial RS485 and enables digital communication with a microprocessor system if present, in standard ModBUS.

A maximum number of 64 devices may be installed in the same line, by setting different addresses.

Cyber is pre-calibrated keeping record of the following basic information written in the Microprocessor's memory:

- Lot/serial number
- Calibration date
- Zero value
- Span value
- Alarm thresholds

All the above are written in the registries and are available for reading using the digital output.

#### *Other outputs available in TTL:*

- 3 Alarm thresholds
- Fault condition
- Sensor end of life as fault (optional depending on the application)

All the above TTL outputs are open collector outputs (maximum 10mA) so they should be used as low power driving signals, that cannot be used to drive directly a relay.

### *Temperature compensation*

As standard, the first board for the electrochemical cells version, is provided with a thermistor calculated for making the temperature compensation for the main sensors.

Exception makes the O<sub>2</sub> sensor that is not temperature compensated as the drift in temperature may be ignored.

### *Auto-zero*

In the device's software a special function is implemented for the monitoring of the zero value shift. This value may vary due to many factors and it is important that the readout curve is always reflecting the sensor behaviour in the right way.

Should there is a shift going up, every 30 minutes a check-up is being done in automatic. If this drift is bellow 2% of the full scale value, it will be zeroed, otherwise it will be shown as readout.

Nevertheless, no auto-zero will be executed anymore should the sum of the auto-zeroes reaches 5% of the full scale value. In this case the real value will be shown and treated as gas presence.

The same for a shift going down, every 3minutes a check-up is being executed. Same as above, should the drift is bellow 2% of the full scale value, it will be zeroed.

In this case, should the drift is leading to a readout touching 700mV, a Fault condition will be activated.

### *Calibration*

By default the board is factory calibrated no matter the sensor provided, with the alarm thresholds set at 10/20/30% of the full scale value, for Alarm 1/2/3 respectively.

In order to recalibrate, two options are available:

- using the software package together with the calibration board.
- Using the calibration keypad, directly connected to the Cyber device.
- 

In the first case the assembly will be connected through the calibration board to a serial port of the PC. For more details see the setup SW manual.

During the calibration procedure, either by means of the software or by means of the keypad, the user will be able to set the following parameters:

- Zero
- Span
- Alarm thresholds

Real time reading of the concentration is also possible.

### 3. Field of use

---

The *4-20mA Cyber® transmitter* device is a component, designed to be used for the detection of flammable gases, vapours, mists and/or combustible particles as well as for toxic atmospheres and lack of oxygen.

The device has no IP protection, so this should be taken care of when designing the incorporating instrument.

Neither the device is certified in any way for classified atmospheres. The *4-20mA Cyber® transmitter* device should be certified by the instrument maker, together with the gas detector that will be part of, should there is the necessity to be used in classified areas.

For this kind of applications as an option there is available an ATEX certified head and therefore the device becomes a *Cyber® Head*.

The *Cyber® Head* is also a component, but it is certified for being used in classified areas according to the ATEX directive.

### 4. Standards

---

The *4-20mA Cyber® transmitter* device was designed in consideration to the following standards:

EN50194, EN50291.

The *Cyber® Head* is conform with the following standards:

EN60079-0 (2006), EN60079-1 (2004), EN61241-0 (2006), EN61241-1 (2004)

## 5. Technical specification

Technical specifications		
<i>Sensing element</i>		
Electrochemical cell	Carbon monoxide	NT-CO/NT-CO-LI/NT-CO-2F
	Hydrogen Sulphide	NT-H2S/NT-H2S-1/NT-H2S-2F
	Ammonia	NT-NH3
	Nitrogen Dioxide	NT-NO2/NT-NO2-2F
	Other toxic gases	Various sensor types from other manufacturers on request
Catalytic sensor	NEMOTO single header catalytic sensor, type NP-XXS, NP-XXSM, NENAPXXA	
Measurement range	Electrochemical cell	- Depending on sensor specification
	Catalytic sensor	- 0-100% LEL
Power supply	+12 VDC or +24VDC	
Current consumption	On board sensor	Current consumption
	NT-CO/NT-H2S/NT-NH3/NT-NO2	mA
	NT-CO-2F/NT-H2S-2F/NT-NO2-2F	mA
	NP-17S	
	NP-30S	
	NP-18S	
	NENAP50A	
Microprocessor	12 bit	
Visual indications	LED output available for status information	
Analogue output	4-20mA output - current source	
Digital outputs	RS485 - MODBUS protocol 3 threshold alarms - TTL outputs FLT signal – TTL output	
Auto zero routine	Zero drift compensation	
Sensor information	Lot/serial number Calibration date Span factor Alarm thresholds	
Digital filter	Sampled values variable average	
Precision	+/- 5% full scale or according to standards	
Repeatability	+/- 5% full scale or according to standards	
Warm-up time	Max. 5 minutes	
Stabilization time	Less than 2 minutes	
Response time	According to sensor manufacturer specification	
Storage temperature	-25 / + 60 °C	
Operating temperature	-10 / + 50 °C	
Relative humidity range	20-90 % Rh / 40° C	
Pressure range	90-110 KPa	
Air velocity	<0.1 – 0.5 m/s	

## 6. Mechanical specifications

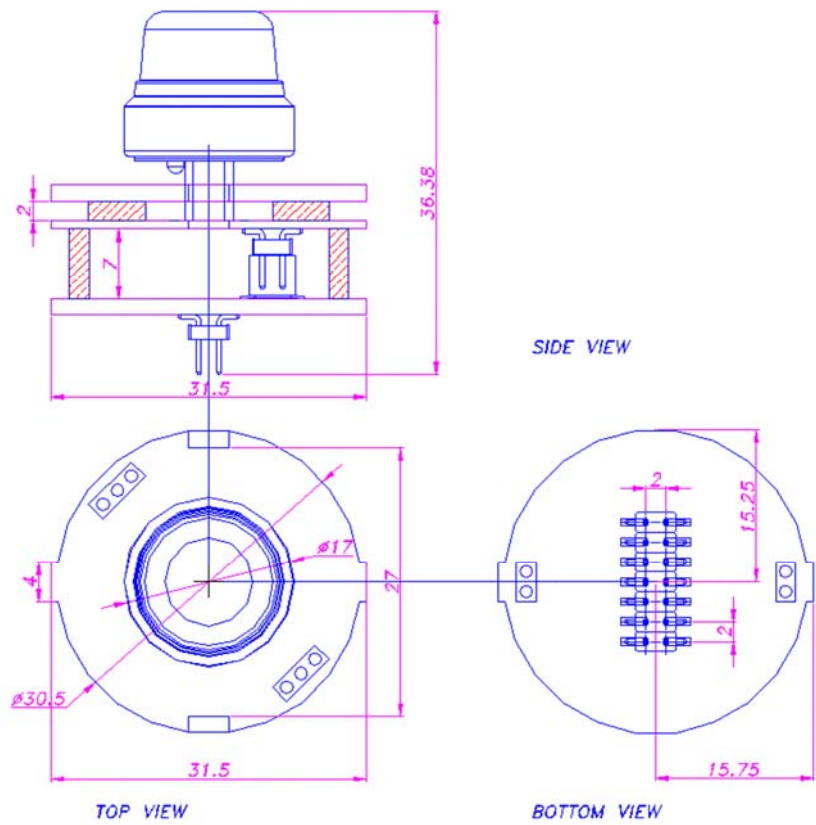

Figure 6.1 Single header industrial catalytic sensor for combustible gases;

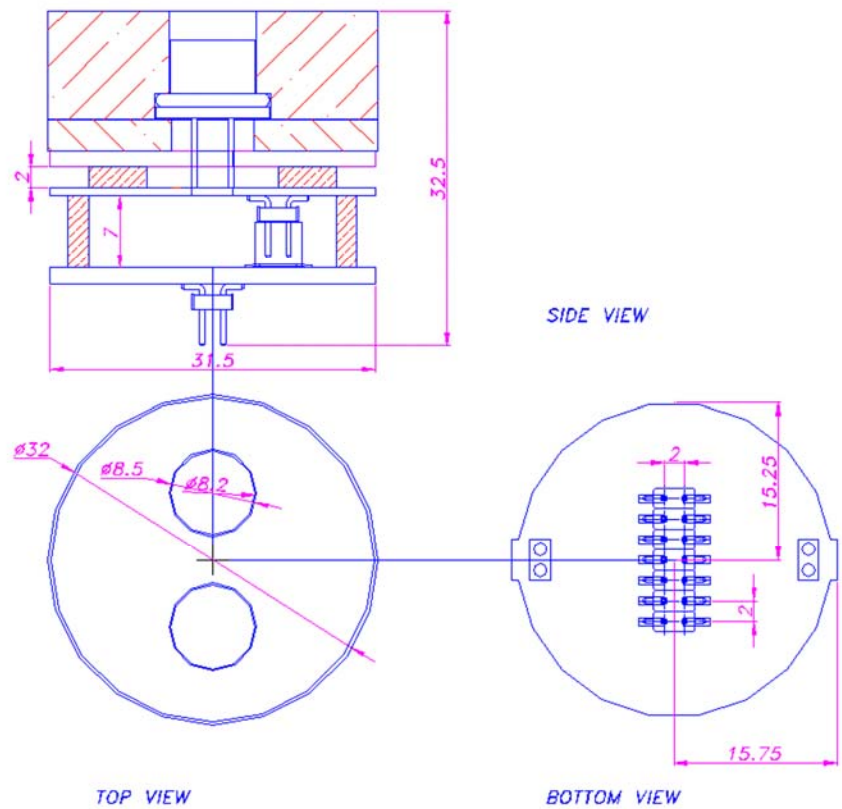

Figure 6.2 Twin industrial catalytic sensor for combustible gases;

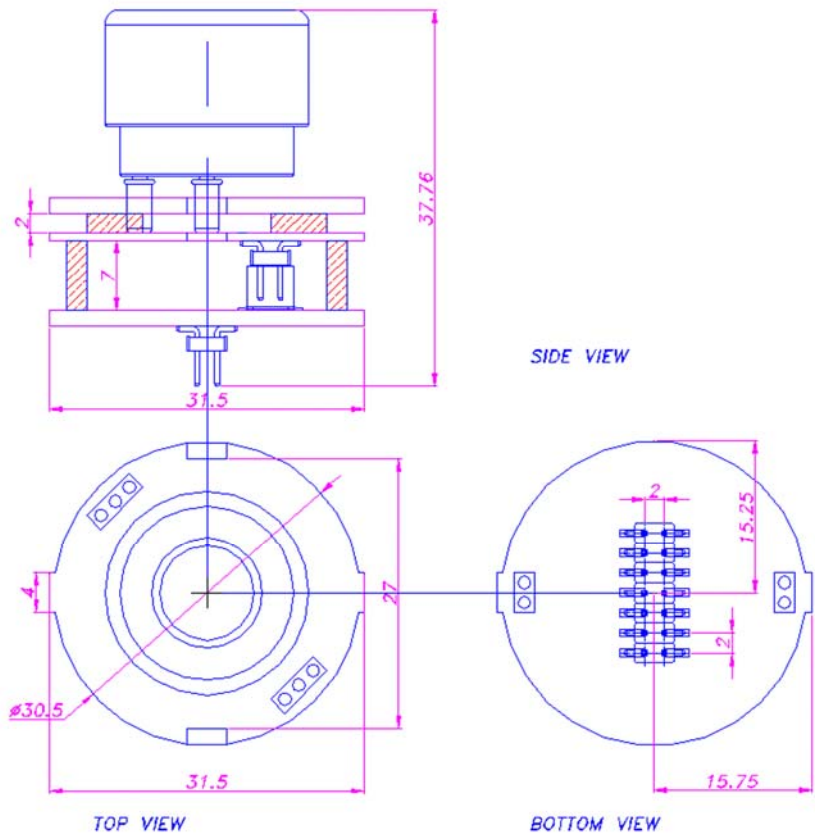

Figure 6.3 Electrochemical cell, 4 series type, for toxic gases detection;

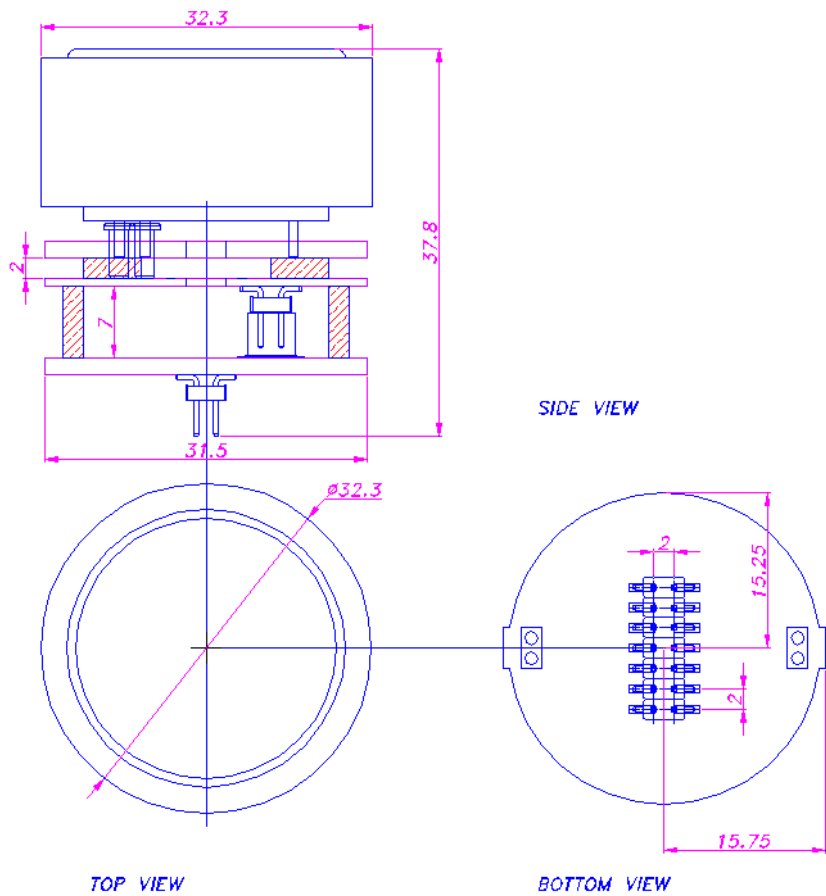

Figure 6.4 Electrochemical cell, 7 series type, for toxic gases detection;

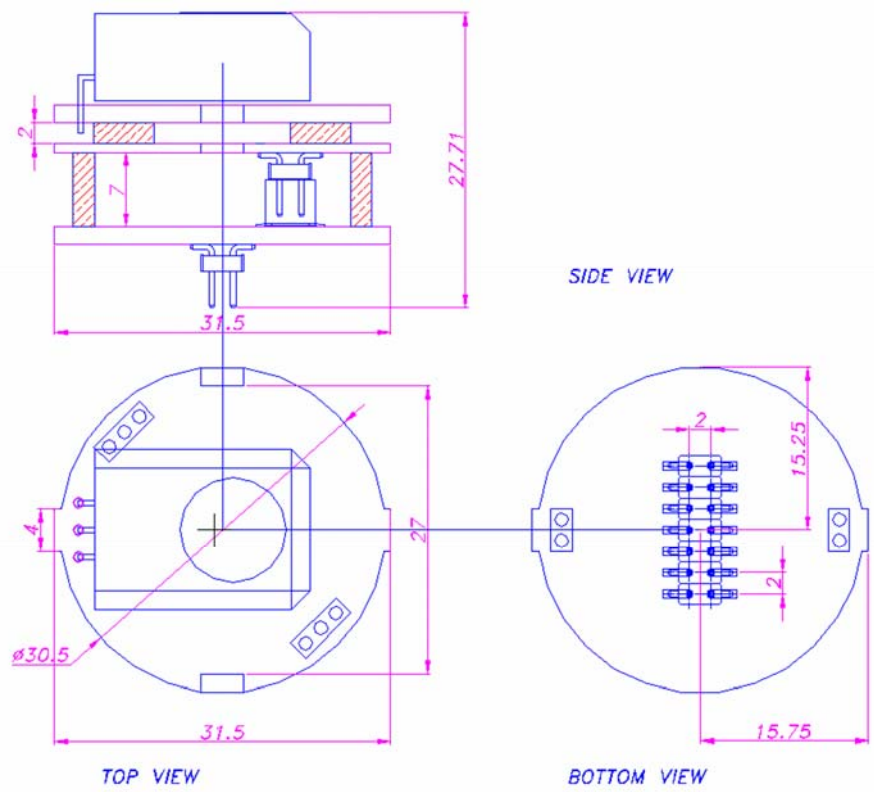

Figure 6.5 Electrochemical cell, flat series type, for toxic gases detection

## 7. Installation and electrical connections

### 4-20mA transmitter

The 4-20mA Cyber transmitter was designed to be used as part of a gas detection instrument. It should be mounted in an appropriate case or in a detection head, provided with power supply unit 12V or 24V, and terminals for connecting the instrument to the control panel.

### PIN-OUT

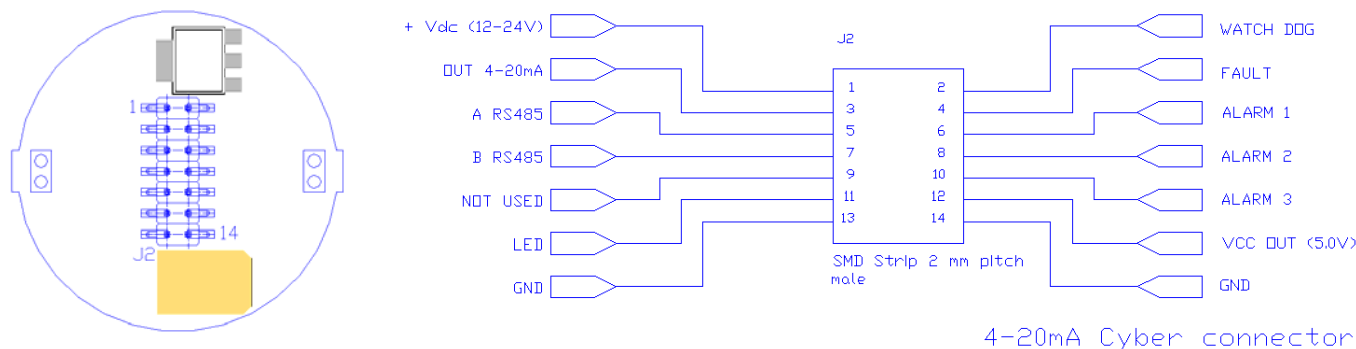

Figure 7.1. 4-20mA board connector and overview.

The signals on the board pin-out according to the drawing above:

PIN 1.	VDC (12-24V)	- Power supply 12-24V <sup>(1)</sup> .
PIN 3.	OUT 4-20mA	- Proportional current output 4-20mA <sup>(2)</sup> .
PIN 5.	A RS485	- A connection to RS 485.
PIN 7.	B RS485	- B connection to RS 485.
PIN 9.	NOT USED	
PIN 11.	LED	- LED output for an external LED of 5-10mA <sup>(3)</sup> .
PIN 13.	GND	- Ground connection.
PIN 2.	WATCH DOG	- repeats the internal watch dog of the microprocessor. Normally stays in logical level "1". Switches to "0" should the watchdog activates.
PIN 4.	FAULT	- TTL output. Normally "1", goes to "0" in case of fault / under-scale / over-range.
PIN 6.	ALARM 1 exceeding.	- First Alarm level <sup>(4)</sup> . TTL output, normally "1", goes to "0" in case of alarm level 1 exceeding.
PIN 8.	ALARM 2 exceeding.	- Second Alarm level <sup>(4)</sup> . TTL output, normally "1", goes to "0" in case of alarm level 2 exceeding.
PIN 10.	ALARM 3 exceeding.	- Third Alarm level <sup>(4)</sup> . TTL output, normally "1", goes to "0" in case of alarm level 3 exceeding.
PIN 12.	VCC (5.0V)	- Voltage supply output (current limit 100mA).
PIN 14.	GND	- Ground connection.

## Cyber head

The Cyber head was designed to be used as part of a gas detection instrument also. The same as the Cyber transmitter, it is a component, but it is covered by an ATEX certification. It is supposed to be mounted in an appropriate case, provided with power supply unit 12V or 24V, and terminals for connection to the control panel.

The head's cable is potted in the stainless steel head. The wires are coming out on a 2.54 mm female connector as follows, looking towards the female connector coming out of the potting:

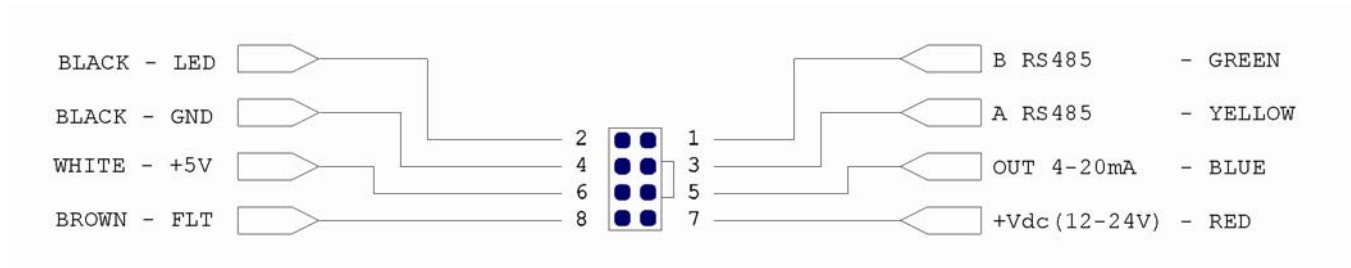

Figure 7.2. Cyber head cable connector.

The signals on the Cyber head wires, according to the drawing above:

- 1 - GREEN B RS485 - B connection to RS 485.
- 3 - YELLOW A RS485 - A connection to RS 485.
- 5 - BLUE OUT 4-20mA - Proportional current output 4-20mA <sup>(2)</sup>.
- 7 - RED VDC (12-24V) - Power supply 12-24V<sup>(1)</sup>.
  
- 2 - BLACK LED - LED output for an external LED of 5-10mA <sup>(3)</sup>.
- 4 - BLACK GND - Ground connection.
- 6 - WHITE VCC (5.0V) - Voltage supply output (current limit 100mA).
- 8 - BROWN FAULT - TTL output. Normally "1", goes to "0" in case of fault / under-scale / over-range.

## NOTES:

- (1) The power supply may be at any level between 12V and 24V limited as minimum 10V and maximum 30V.
- (2) The current output is the source type. To make the calibration of the 4-20mA output, make sure a 200 Ohm resistor is connected between PIN 3 and GND for the 4-20mA Cyber transmitter, or between the blue wire and GND (pin5 of the cable connector and pin 4 respectively).
- (3) LED output to be used for driving an external LED giving information about the device status.
- (4) By default the three alarm levels are set as 10/20/30% Full Scale respectively for ALARM 1/2/3.