



Single Board CYBER[®]
Cyber[®] Module for flammable, toxic and O2 gas detection

NET
DRAFT version 2.1 - 2008



1. Introduction

Single board Cyber® is a microprocessor based product, designed for gas sensing applications. It may be used for the detection of toxic gases, using electrochemical cells and for flammable gases, using catalytic gas sensors. The raw signal input from the sensor is processed by the microprocessor, which also stores sensor's information.

The readout data is available both in analogue and digital format.

Information such as alarm thresholds, fault conditions, calibration data etc are available in the microprocessor's registries.

Single board Cyber® single board is built around a 12bit microcontroller and it is a device that was meant to be used mainly in commercial and/or "light industrial" applications. The device was designed to be the "heart" of a standard detector. It is powered at 5V.

The main features of the single board Cyber are as follows:

- powered at +5V
- proportional voltage output—standard 0.8 to 4V
- TTL serial communication
- Fault and Alarm thresholds TTL programmable outputs,
- external LED output.

2. Operation

General description

The single board Cyber® device consists of a sensor mounted on a microprocessor based PCB. Depending on the gas sensor technology, there are two versions of the board: one for the catalytic sensors and another one for electrochemical cells.

Versions

The board designed for the catalytic sensors will be used for the detection of flammable gases. The whole range of Nemoto catalytic single header sensors may be fitted on this board.

The resulting device will monitor a flammable gas in the range 0-100%LEL.

The board designed to accommodate the electrochemical cells, may fit both the Nemoto electrochemical cells and 7 series like cells, for gases for which Nemoto doesn't cover the detection.

The resulting device will be able to monitor a wide range of toxic gases as well as oxygen. The detection range depends on the sensor fitted. The standard applications cover:

- CO detection range 0-300ppm
- H₂S detection range 0-100ppm
- NH₃ detection range 0-100ppm
- NO₂ detection range 0-20ppm
- O₂ detection range 0-25%v/v

The board should be powered at a 5V, making sure that the power supply gives at least 5V. The device is provided with a voltage stabilizer set for 5V. This way the voltage reference used for calibration is always the same independently on the external power supply.

A number of versions of the device are available, depending on the gas sensor mounted.

The various options are presented in the drawings of Chapter 6 - Mechanical specifications.

As signal output there are featured two options:

- Analogue output, featuring a voltage proportional signal from 0.8 to 4V, as for zero to full scale value readout may be read as analogue or digital
- TTL serial line featuring a digital communication in standard ModBUS

Analogue voltage output

The single board Cyber® features a standard voltage output 0.8 to 4V. The output is calibrated so that the readout is 0.8V at zero gas and 4V at full scale.

TTL serial output

On the other hand, a serial line is provided that enables digital communication with a microprocessor system if present, in standard ModBUS.

Cyber is pre-calibrated keeping record of the following basic information written in the Microprocessor's memory:

- Lot/serial number
- Calibration date
- Zero value
- Span value
- Alarm thresholds

All the above are written in the registries and are available for reading using the digital output.

Other outputs available in TTL:

- 3 Alarm thresholds
- Fault condition
- Sensor end of life as fault (optional depending on the application)

All the above TTL outputs are open collector outputs (maximum 10mA) so they should be used as low power driving signals, that cannot be used to drive directly a relay.

Temperature compensation

As standard, the single board Cyber® modules fitted with electrochemical cells are provided with a thermistor calculated for making the temperature compensation for the main sensors. Exception makes the O₂ sensor that is not temperature compensated as the drift in temperature may be ignored.

Auto-zero

In the device's software a special function is implemented for the monitoring of the zero value shift. This value may vary due to many factors and it is important that the readout curve is always reflecting the sensor behaviour in the right way.

Should there is a shift going up, every 30 minutes a check-up is being done in

automatic. If this drift is below 2% of the full scale value, it will be zeroed, otherwise it will be shown as readout.

Nevertheless, no auto-zero will be executed anymore should the sum of the auto-zeroes reaches 5% of the full scale value. In this case the real value will be shown and treated as gas presence.

The same for a shift going down, every 3 minutes a check-up is being executed. Same as above, should the drift be below 2% of the full scale value, it will be zeroed.

In this case, should the drift be leading to a readout touching 700mV, a Fault condition will be activated.

Calibration

By default the board is factory calibrated no matter the sensor provided, with the alarm thresholds set at 10/20/30% of the full scale value, for Alarm 1/2/3 respectively.

In order to recalibrate, two options are available:

- using the software package together with the calibration board.
- Using the calibration keypad, directly connected to the Cyber device.

In the first case the assembly will be connected through the calibration board to a serial port of the PC. For more details see the setup SW manual.

During the calibration procedure, either by means of the software or by means of the keypad, the user will be able to set the following parameters:

- Zero
- Span
- Alarm thresholds

Real time reading of the concentration is also possible.

3. Field of use

The single board Cyber® is a component, designed to be used for the detection of flammable gases, vapours, mists and/or combustible particles as well as for toxic atmospheres and lack of oxygen.

The board has no IP protection, so this should be taken care of when designing the incorporating instrument.

Neither the board is certified in any way for classified atmospheres. The Cyber-TX board should be certified by the instrument maker, together with the gas detector that will be part of, should there is the necessity to be used in classified areas.

4. Standards

The single board Cyber® device was designed in consideration to the following standards: EN50194, EN50291.

5. Technical specification

Technical specifications		
<i>Sensing element</i>		
Electrochemical cell	Carbon monoxide	NT-CO/NT-CO-LI/NT-CO-2F
	Hydrogen Sulphide	NT-H2S/NT-H2S-1/NT-H2S-2F
	Ammonia	NT-NH3
	Nitrogen Dioxide	NT-NO2/NT-NO2-2F
	Other toxic gases	Various sensor types from other manufacturers on request
Catalytic sensor	NEMOTO single header catalytic sensor, type NP-XXS, NP-XXSM, NENAPXXA	
Measurement range	Electrochemical cell	- Depending on sensor specification
	Catalytic sensor	- 0-100% LEL
Power supply	+5 VDC (always higher than 5V. the device is provided with a voltage stabilizer that requires the input voltage to be higher than 5V)	
Current consumption	On board sensor	Current consumption (average)
	NT-CO/NT-H2S/NT-NH3/NT-NO2	55 mA
	NT-CO-2F/NT-H2S-2F/NT-NO2-2F	55 mA
	NP-17S	
	NP-30S	
	NP-18S	
	NENAP50A	
Microprocessor	12 bit	
Visual indications	LED output available for status information	
Analogue outputs	0.8 – 4 V voltage output 3 threshold alarms - TTL outputs FLT signal – TTL output	
Digital outputs	TTL - MODBUS protocol	
Auto zero routine	Zero drift compensation	
Sensor information	Lot/serial number Calibration date Span factor Alarm thresholds	
Digital filter	Sampled values variable average	
Precision	+/- 5% full scale or according to standards	
Repeatability	+/- 5% full scale or according to standards	
Warm-up time	Max. 5 minutes	
Stabilization time	Less than 2 minutes	
Response time	According to sensor manufacturer specification	
Storage temperature	-25 / + 60 °C	
Operating temperature	-10 / + 50 °C	
Relative humidity range	20-90 % Rh / 40° C	
Pressure range	90-110 KPa	
Air velocity	<0.1 – 0.5 m/s	

6. Mechanical specifications

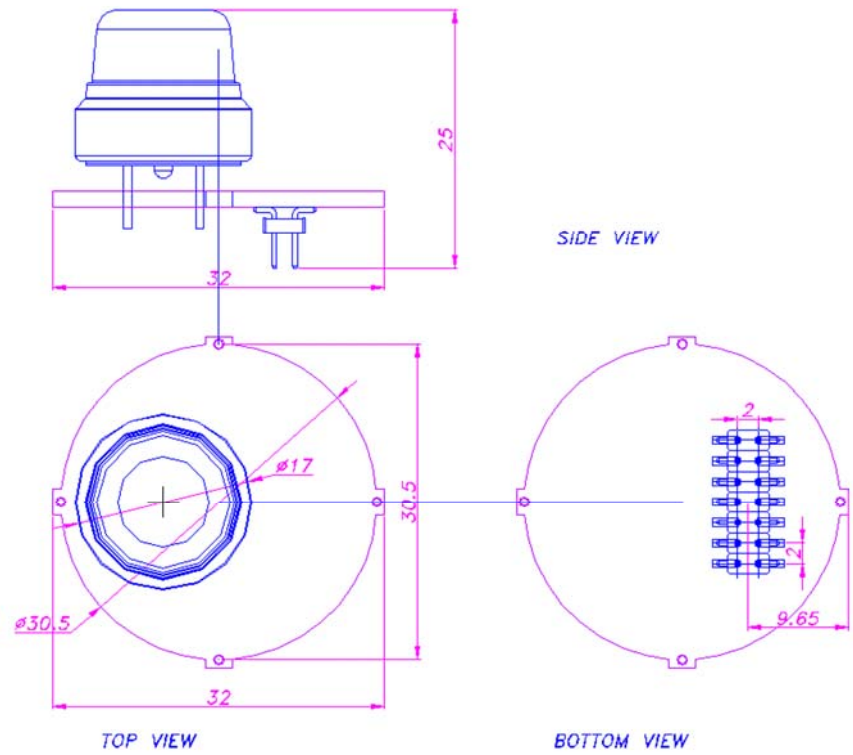

Figure 6.1 Single header industrial catalytic sensor for combustible gases;

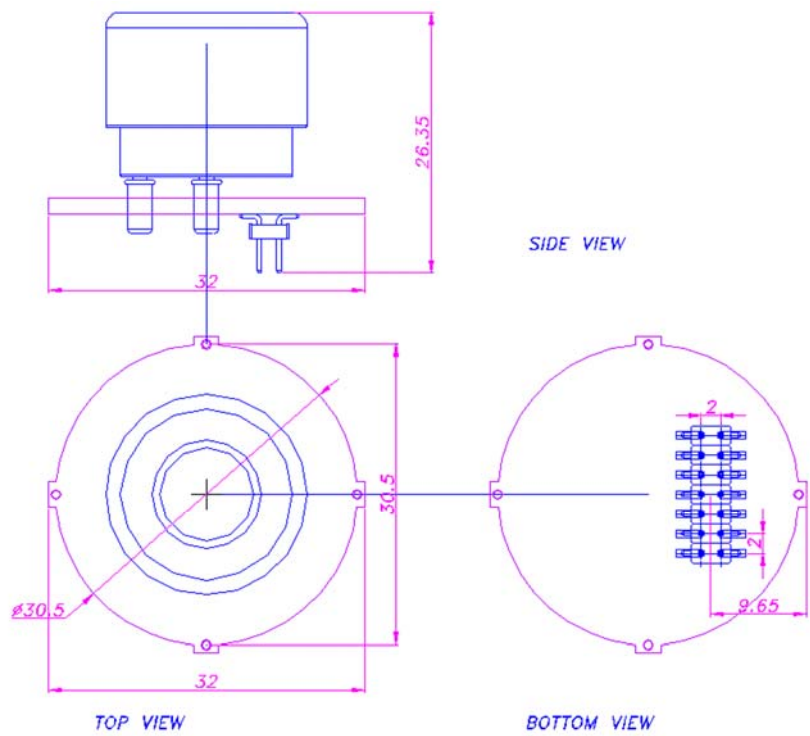

Figure 6.2 Electrochemical cell, 4 series type, for toxic gases detection;

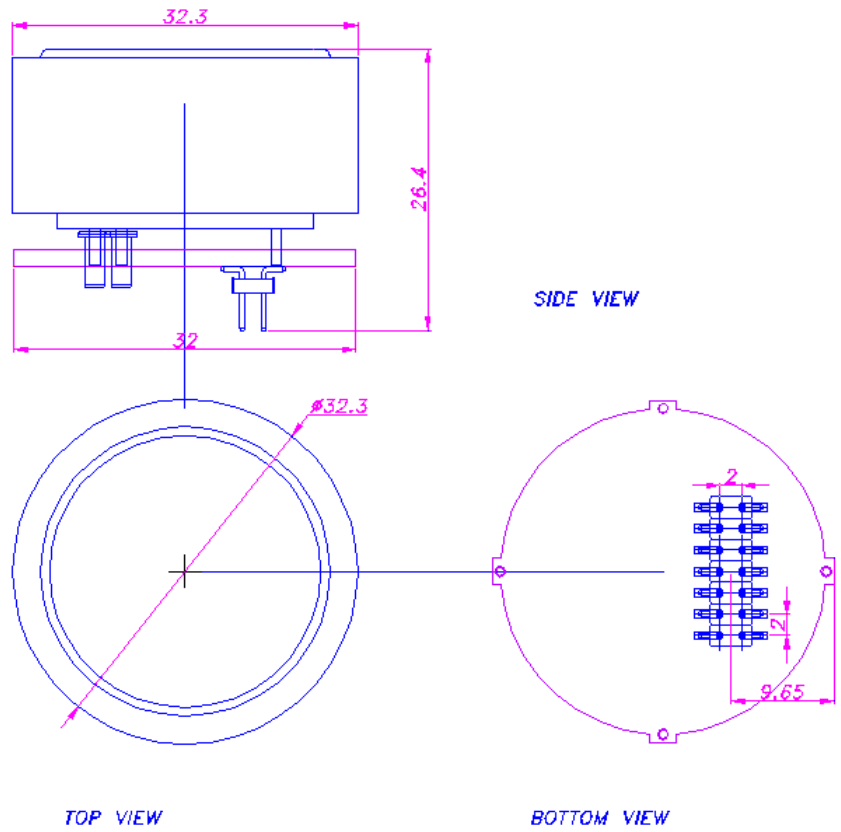

Figure 6.3 Electrochemical cell, 7 series type, for toxic gases detection;

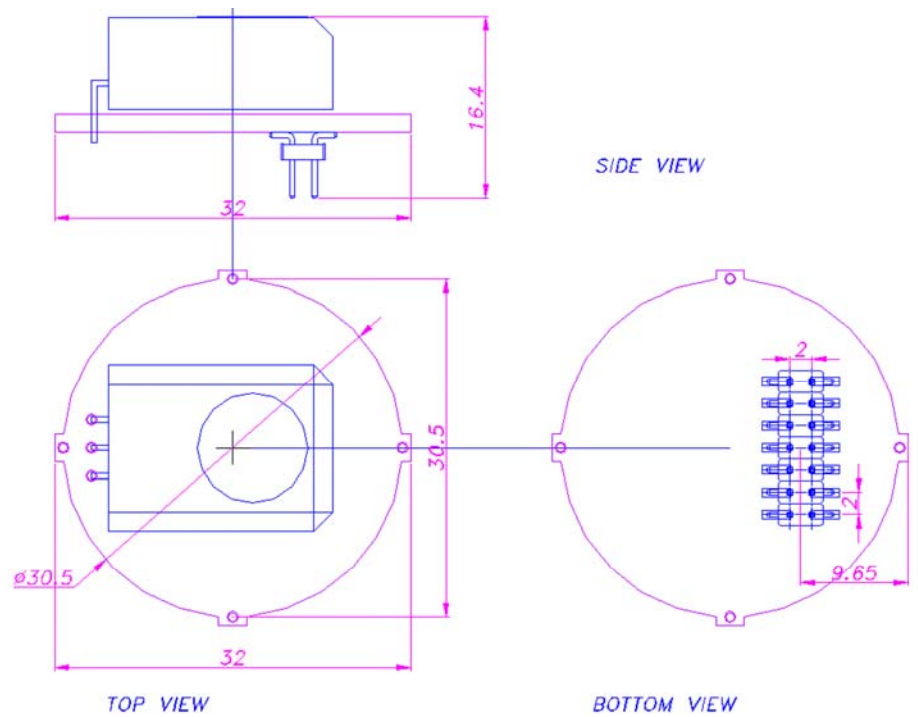

Figure 6.4 Electrochemical cell, flat series type, for toxic gases detection;

7. Installation and electrical connections

The single board Cyber® was designed to be used as part of a gas detection instrument. It should be mounted on a support board, provided with power supply unit, independent or mains based and terminals for connecting the instrument to the driven circuits should there are any.

PIN-OUT

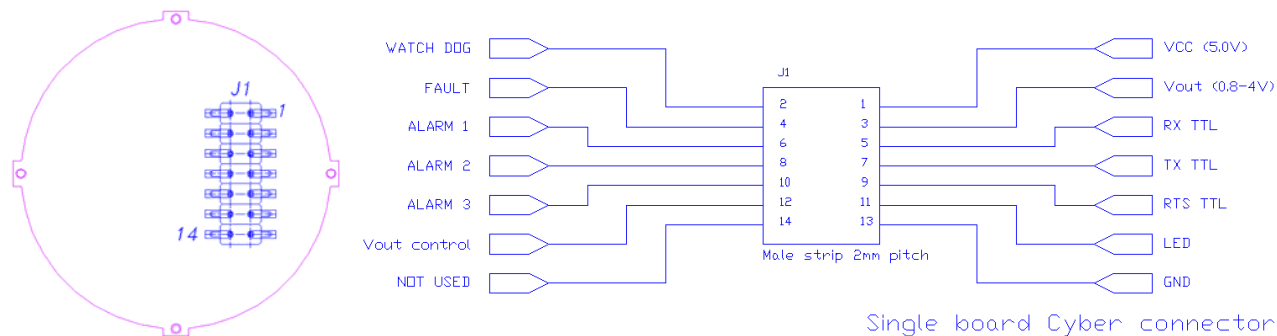

Figure 7.1 Single board Cyber connector and overview.

The board features a 2x7, 2mm gap, male connector with the pin-out as presented in Figure 5.1 above.

The signals on the board pin-out according to the drawing above:

PIN 1.	VCC (5.0V)	- Power supply input 5.0V.
PIN 3.	Vout (0.8-4V)	- Proportional voltage output: 0.8V – zero level / 4V – full scale.
PIN 5.	RX TTL	- RX output in TTL ⁽¹⁾ .
PIN 7.	TX TTL	- TX output in TTL ⁽¹⁾ .
PIN 9.	RTS TTL	- Driver output enable ⁽¹⁾ .
PIN 11.	LED	- LED output for an external LED of 5-10mA ⁽²⁾ .
PIN 13.	GND	- Ground connection
PIN 2.	WATCH DOG	- repeats the internal watch dog of the microprocessor. Normally stays in logical level “1”. Switches to “0” should the watchdog activates.
PIN 4.	FAULT	- TTL output. Normally “1”, goes to “0” in case of fault / under-scale / over-range.
PIN 6.	ALARM 1	- First Alarm Threshold ⁽³⁾ - TTL output . Normally “1”, goes to “0” in case of alarm level 1 exceeding.
PIN 8.	ALARM 2	- Second Alarm level ⁽³⁾ - TTL output. Normally “1”, goes to “0” in case of alarm level 2 exceeding.
PIN 10.	ALARM 3	- Third Alarm level ⁽³⁾ - TTL output. Normally “1”, goes to “0” in case of alarm level 3 exceeding.
PIN 12.	Vout Control	- Input for controlling the Vout level ⁽⁴⁾ .
PIN 14.	NOT USED	

NOTES:

- (1) Pins 5 and 7 on the first board are RX and TX respectively in TTL levels. Together with pin 9, RTS, one has the full control should the digital communication is needed. The communication protocol implemented is standard ModBUS.
- (2) LED output to be used for driving an external LED giving information about the device status. Maximum 10mA current drawn should be considered.
- (3) By default the three alarm levels are set as 10/20/30% Full Scale respectively for ALARM 1/2/3
- (4) By default the Vout range is 0.8-4V. The range may be shifted from 0.4-3.6V to 1.8-5V by means of a resistor net which should be connected as in Figures 7.2, 7.3 that follow.

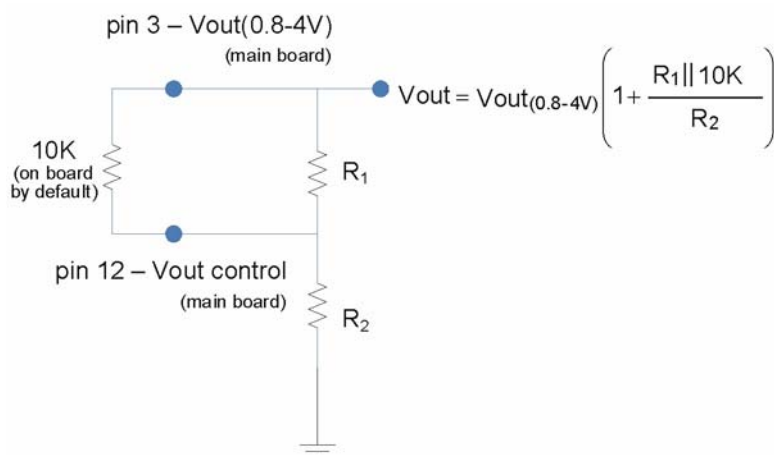

Figure 7.2 Vout value shifted up (in relation to 0.8—4V). The full scale value at maximum 5V.

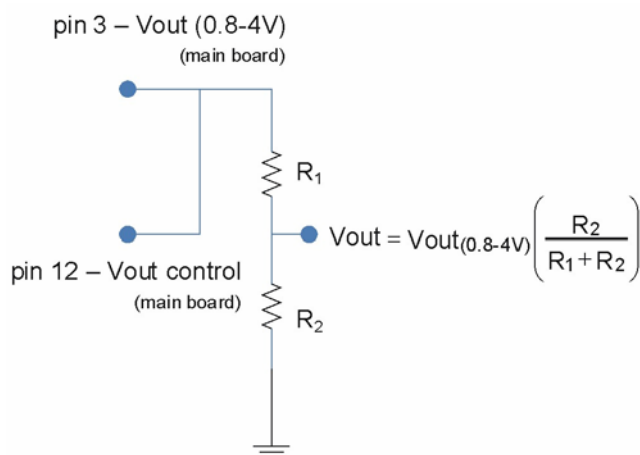

Figure 7.3 Vout value shifted down (in relation to 0.8—4V). The zero value at minimum 0.4V.