



## 4 to 20 mA Analogue Transmitter Boards

### Alphasense "B" Type Toxic & O2-A2 Oxygen Sensors

# Technical Specification



Alphasense 4-20mA analogue transmitters offer the following features:

- ◆ Factory calibration for immediate use
- ◆ Custom-set range to your requirements
- ◆ Wide operating voltage range
- ◆ Low RFI susceptibility

Alphasense 4-20 mA analogue transmitter boards provide a cost effective way for Original Equipment Manufacturers to engineer transmitter heads for fixed installation systems. The range of sensors are shown below. The boards supplied with sensors are pre-calibrated.

The 4-20 mA output signal provides an equivalent performance to that shown in individual sensor data sheets provided for each of the Alphasense "B" Series Toxic and O2-A2 oxygen sensors.

Each board is provided with set of mounting pillars for location of the board onto an enclosure. To allow OEMs to distinguish their product from other offerings, the sensor to gas aperture design is left to the OEM to execute.

GAS	SENSOR TYPE B	MAXIMUM GAS CONCENTRATION (ppm)
Carbon Monoxide	CO-BF	5,000
	CO-BX	2,000
Hydrogen Sulfide	H2S-B1	200
	H2S-BH	50
	H2S-BE	2,000
Sulfur Dioxide	SO2-BF	100
Nitrogen Dioxide	NO2-B1	20
Chlorine	CL2-B1	20
Nitric Oxide	NO-B1	250
Phosphene	PH3-B1	10
Ethylene Oxide	ETO-B1	100
Oxygen	O2-A2	15-25%

Specify preferred full scale gas concentration with your order, up to maximum concentration.



# 4 to 20 mA Analogue Transmitter Boards

Technical Specification

Figure 2 Transmitter Board Dimension Details

### Oxygen Transmitter

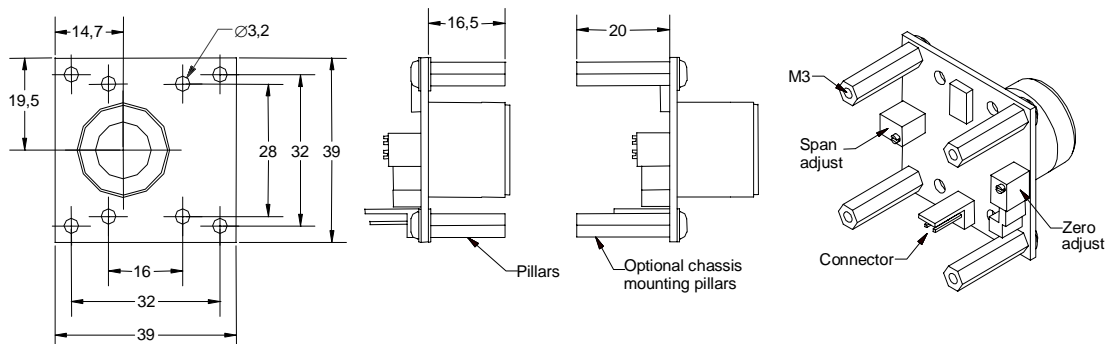

### Toxic Gas Transmitter

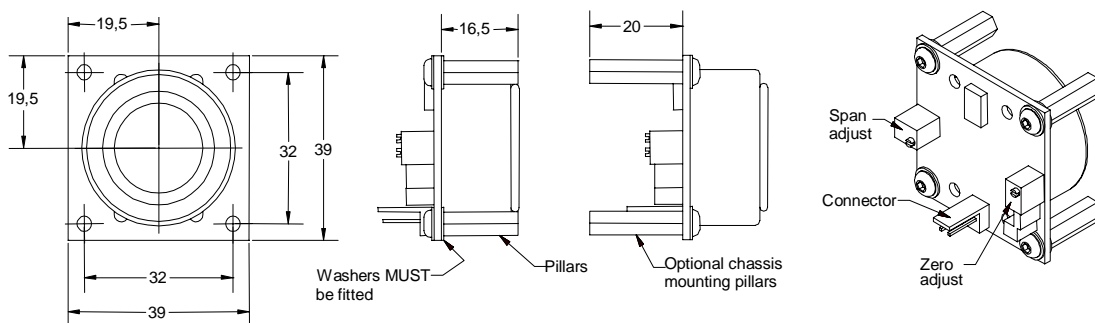

All dimensions in mm  $\pm 0.15$

Input voltage required	+7.5 to +35VDC
Output at zero gas concentration (or 15% Oxygen)	4mA (user adjustable)
Output at full scale (or 25% Oxygen)	20mA (user adjustable)
Setability/stability	<0.5mA (<0.25% full scale)
Maximum load @ 20mA, 24VDC	825 ohms
Supply voltage dependence	< $\pm 0.2\%$ output from +7.5 to +35VDC
Connector	2 pin Molex plug (ref. 22-27-2021) supplied with leads
Transmitter current requirement	<100uA
Operating conditions	See sensor data sheet specifications
Calibration	Multiturn zero and span potentiometers
Power supply protection	Diode protection to voltage regulator
No-power equivalent circuit (for toxic gas versions)	Sensor short-circuited during power down
Full-scale gas concentration	Precalibrated (see table over)

### Conformal Coating

The circuit board is conformally coated with an acrylic sealant to ensure reliable operation in extreme conditions.

**NOTE:** as applications of use are beyond our control, the information provided is given without legal responsibility. Customers should test under their own conditions, to ensure that the sensors and transmitters are suitable for their own requirements.

For further information on the performance of sensors in the Alphasense range or any other subject, please contact Alphasense Ltd. For Application Notes visit "[www.alphasense.com](http://www.alphasense.com)"

*In the interest of continued product improvement, we reserve the right to change design features and specifications without prior notification. The data contained in this document is for guidance only. Alphasense Ltd accepts no liability for any consequential losses, injury or damage resulting from the use of this document or the information contained in it (©ALPHASENSE LTD) Doc. Ref. 4-20mA Analogue/APR09*