

4-20mA Transmitter for Toxic Sensors UMTOX-1 Issue 4

1 INTRODUCTION

The Transmitter PCB includes circuitry for a three electrode toxic sensor to convert the μA output signal from the sensor to a 2-wire 4-20mA signal. The transmitter board includes 4 mounting pillars that may be removed if not required.

Alphasense 4-20 mA transmitters offer convenience and easy maintenance for toxic sensors:

- Transmitters are shipped pre-calibrated for immediate use.
- Circuitry includes onboard voltage regulator and uses low power two-wire transmitter systems, allowing the simplest possible wiring format.
- Small circuit board size allows smaller sensor housing.
- Conformally coated circuit board for environmental protection of circuit.
- Low power circuitry with excellent performance means no degradation of sensor performance due to electronics.
- Amplification of the sensor signal reduces noise pick-up and RFI/EMI susceptibility.

Besides periodic sensor re-calibration, the transmitter electronics require no maintenance throughout the lifetime of the sensor. The sensor can be replaced at the end of the sensor working life. Re-calibration is required when the sensor is changed. See section 6.

Please read these instructions to ensure correct installation, use and calibration of your gas sensor/ transmitter.

2.1 Transmitter Specification

Input Voltage Required	+7.5 to + 35 VDC
Output at zero gas concentration	4mA (user adjustable)
Output at full-scale	20mA (user adjustable)
Setability /stability	<0.05mA (<0.25% FS)
Maximum load @ 20 mA, 24 VDC	825 ohms (see note)
Supply voltage dependence	< ± 0.2 % output from +7.5 to +35 VDC
Connector	2 pin Molex plug (ref. 22-27-2021)
PCB current requirement	<100 μA
PCB dimensions	39mm (dia.) x 19 mm (height)
Operating conditions	See sensor specification
Calibration (shipped pre-calibrated)	multi-turn zero and span potentiometers
Power supply protection	Diode protection to voltage regulator
No-power equivalent circuit	Electrodes short- circuited via FET

2.2 Range/Options

Sensor and transmitter boards are shipped from Alphasense pre-calibrated. You may wish to confirm calibration. Standard available ranges are listed below:

Sensor	Ordering Code (includes sensor)	Full-Scale Gas Concentration (ppm)	Gain
CO-BF	THCO-BF	1000	Low
CO-BF	TLCO-BF	100	High
H ₂ S-BE	THH ₂ S-BE	1000	Low
H ₂ S-B1	THH ₂ S-B1	200	Low
H ₂ S-B1	TLH ₂ S-B1	25	High
SO ₂ -BF	THSO ₂ -BF	100	Low
SO ₂ -BF	TLSO ₂ -BF	20	High
NO ₂ -B1	THNO ₂ -B1	50	High
NO ₂ -B1	TLNO ₂ -B1	10	High
CL ₂ -B1	TLCL ₂ -B1	10	High

Table 1: Transmitter ordering code

Although the sensor and transmitter are pre-calibrated and the ranges are preset, it is possible to change range by adjusting the zero and gain potentiometers, which changes the circuit gain.

Different sensors can be fitted to a transmitter board; if the gain is in the same category (low or high), then only re-calibration is necessary. If the sensor gain is different, then contact Alphasense for instructions on how to change range.

Nitrogen dioxide and Chlorine (NO₂ and Cl₂) sensors give negative outputs, so Cl₂ and NO₂ transmitters (THNO₂-B1, TLCL₂-B1 and TLNO₂-B1) will not accept other sensors (CO, H₂S, SO₂), since they have an additional op amp stage to correct for this inverted output. See section 6.

3 Set Up

3.1 Mechanical Mounting

Transmitters are mounted to your housing using the four pillars pre-mounted to the PCB. Two sets of mounting holes are provided so that the sensor/PCB can be fixed to either the housing top (using the locating holes in the corner of the PCB) or to the base of the housing (using either set of locating holes). Figure 1 below shows mounting hole locations (dimensions are in mm). Figure 2 diagrams the sets of locating holes; normally the outer holes are used for mounting, while the inner e in the same location as the earlier issue of this PCB, allowing backward compatibility with the earlier PCB design.

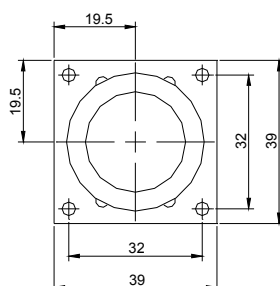

Figure 1. Outer mounting hole locations.

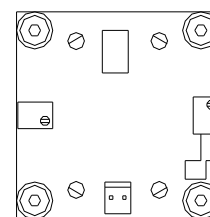

Figure 2. Inner and outer mounting holes.

The pillars are tapped to accept an M3 pan head screw. We recommend a screw length that is at least 8mm to ensure rigid fixing.

It is good practice to hold the pillar when screwing into the pillars to stop the pillar from rotating on the PCB. It may be easier to remove the sensor whilst screwing the circuit board pillars to your housing.

If you move the pillars, ensure that if mounting to the lid of your housing that you include the washer between the pillar and PCB to ensure correct height of the pillar assembly. See figures 3 and 5.

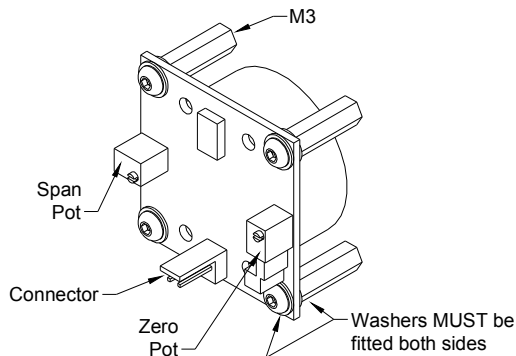

Figure 3. Mounting pillar configuration for attaching to the lid of an enclosure.

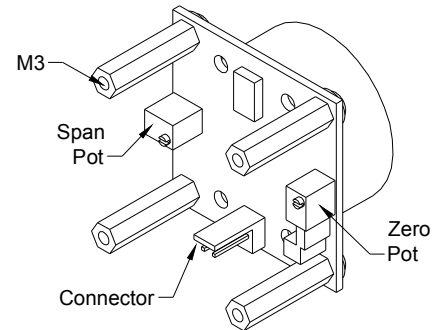

Figure 4. Mounting pillar configuration for attaching to the base of an enclosure.

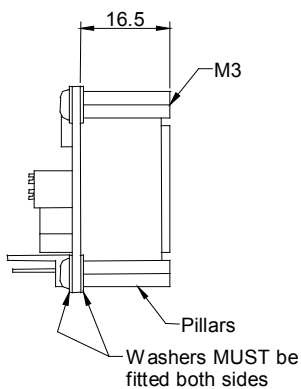

Figure 5. Side view of mounting to lid of an enclosure.

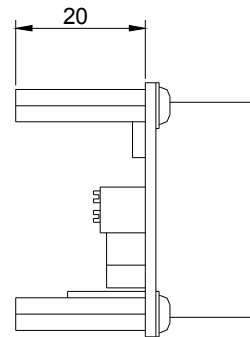

Figure 6. Side view of mounting to the base of an enclosure.

Allow 20 minutes after plugging the sensor back into the board for the output to stabilise.

Ensure that the sensor is sealed securely to the top face of your housing.

The O-ring supplied with your transmitter sensor should be used to ensure an airtight seal, avoiding any access of toxic or corrosive gases to the circuit board and the housing interior.

3.2 Connection and Wiring

Power to the transmitter board is via a Molex 2-pin mini plug (type 22-27-2021: supplied with the transmitter). Connect using a screened, two-core cable to the wires (black is ground, red is positive) by either soldering or using a screw terminal block. Twisted pairs can be used for shorter cable lengths. These leads can be shortened or extended as needed.

3.3 Power Supply

Your power supply must be between 7.5 and 35 VDC with less than 0.2V ripple.

Do not supply mains AC power to this unit: this will destroy the transmitter and void the warranty.

The transmitter is protected against incorrect polarity but will not function if you have reversed the power supply wires by connecting the Molex plug incorrectly to the transmitter board socket.

When selecting the power supply voltage, you must not exceed the maximum total loop resistance, which includes your measuring resistor used to change the 4-20 mA current into a measured voltage.

The transmitter requires a minimum of 7.5 volts to operate; therefore, the maximum potential drop allowed across your sensing resistor and cable is:

$$(\text{power supply voltage}) - (7.5\text{V})$$

Assuming full-scale deflection at 20 mA, use Ohm's law to calculate the maximum loop (cable plus sensing resistor) resistance allowed.

4 Correct Usage and Maintenance

Ensure there is a good gas seal between the sensor and the housing; also if the sample is pumped, then ensure that the flow rate is sufficient. Alternatively, the sample gas can be allowed to diffuse to the front face of the sensor. The table below shows the recommended gas flow rate in standard cubic centimetres per minute (sccm). Higher flow rates may be used, but beware that pulsing flow and higher-pressure drops may lead to more erratic readings.

Gas	Flow Rate (sccm)
CO	300 to 500
H ₂ S	400 to 700
SO ₂	400 to 700
Cl ₂ , NO ₂	400 to 700

Table 2: Pumped gas recommended flow rates

The only maintenance required is changing of the O-ring if it has been exposed to extreme environments for long periods (this O-ring should last the lifetime of the sensor in normal conditions). In addition, if the top dust/oil filter has become badly contaminated then contact Alphasense for replacement dust filter (section 5).

5 Reordering Part Numbers

Replacement sensor O-rings and dust/oil filters can be ordered by quoting the part numbers below.

Part Number	Description
033-0002-00	Replacement O-ring
024-0011-00	Self-adhesive dust/oil filter

Table 3: Replacement Part Numbering

6 Calibration

The 4-20mA transmitter is shipped pre-calibrated to the range shown in Table 1. Periodic re-calibration is required for all gas sensors, especially in safety-critical applications.

To Calibrate:

- 1 First ensure that the power supply is connected correctly and a tight fitting flow hood is in place.
- 2 Ensure that a high quality zero gas source is available (e.g. cylinder of zero air or cleaned and scrubbed compressed air) and a bottle of calibration gas with validated accuracy (see Table 5 below).
- 3 Apply zero gas for 10 minutes at the flow rate shown in Table 2. Using a small screwdriver, adjust the zero potentiometer (RP2) until the reading is 4.00 ± 0.05 mA. See figure 1, attached to this manual.
- 4 Apply test gas for ten minutes; the recommended test gas concentration for calibration is shown below in Table 4. Adjust the span potentiometer (RP1) with a small screwdriver until the reading is within ± 0.05 mA of the Span Calibration Point shown in Table 4 if you are using the recommended concentration.
- 5 Although it should not be necessary, it is good practice to recheck the zero after setting the span to ensure that the output is still 4.00 ± 0.05 mA in clean air ("zero gas"). Allow at least 10 minutes for full recovery to zero after the calibration gas has been removed.

Transmitter	Full-Scale (ppm)	Calibration gas (ppm)	Span Cal Point (mA)
THCO-BF	1000	400	10.40
TLCO-BF	100	100	20.00
THH2S-BE	1000	400	10.40
THH2S-B1	200	50	8.00
TLH2S-B1	25	20	16.80
THSO2-BF	100	50	12.00
TLSO2-BF	20	10	12.00
THNO2-B1	50	25	12.00
TLNO2-B1	10	5	12.00
TLCL2-B1	10	5	12.00

Table 4: 4-20 mA Transmitter Span Calibration

7 Warranty

Transmitters are warranted for two years. Sensors are warranted separately. If you have any difficulties or problems then contact:

Customer Support
Alphasense Limited
Sensor Technology House
300 Avenue West
Skyline 120
Great Notley
Essex
United Kingdom
CM77 7AA

Tel: +44 (0) 1376 556 700
Fax: + 44 (0) 1376 335 899
email: sensors@alphasense.com

8 Attachments

Figure 7 Circuit diagram

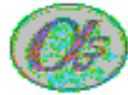
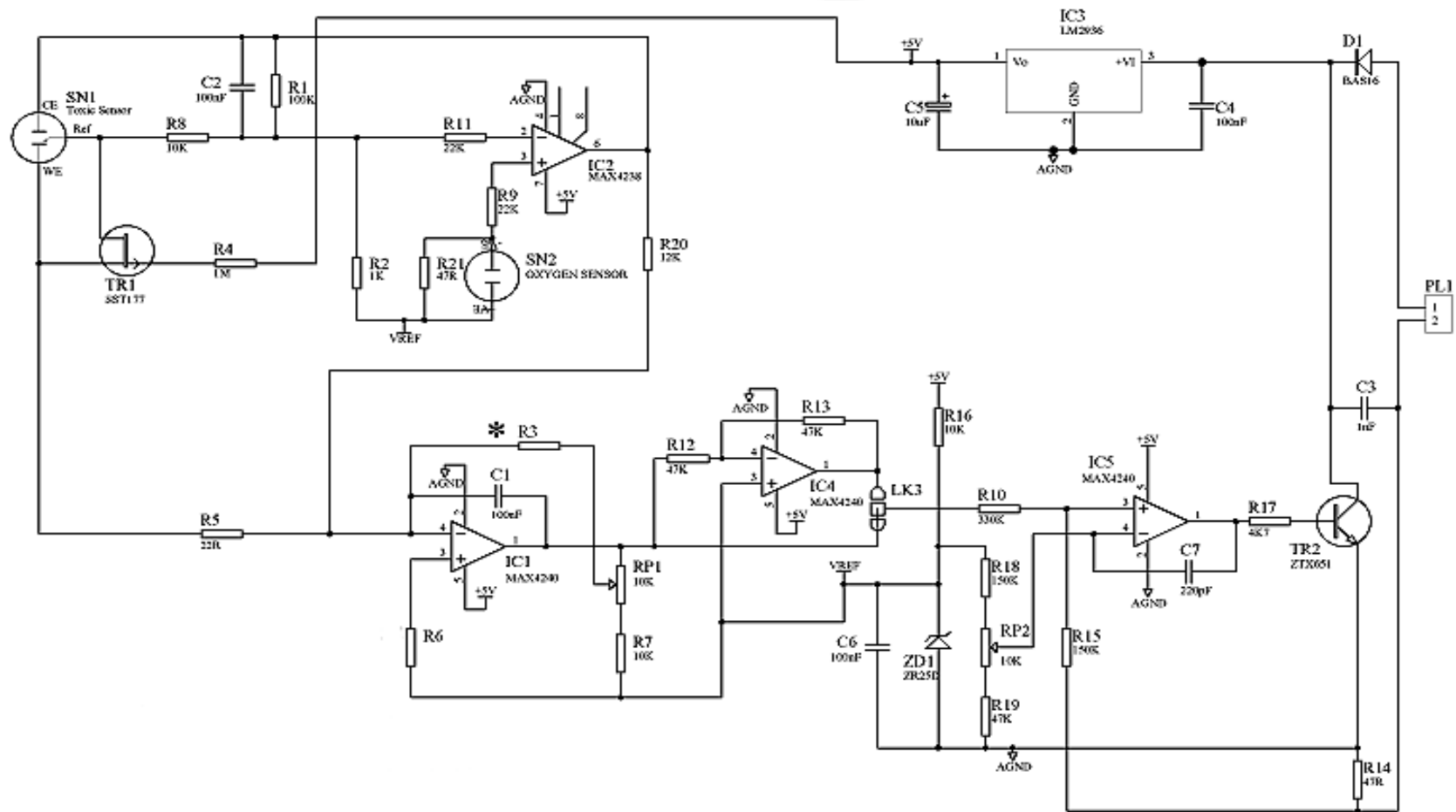

Alphasense Ltd

Sensor Technology House, 300 Avenue West, Skyline 120, Great Notley, Essex, UK CM77 7AA
 Tel: +44 (0) 1376 556 700 Fax: +44 (0) 1376 335 899 e-mail: sales@alphasense.com web: www.alphasense.com