

Key Features & Benefits:

- Meets the requirements of ISO 80601-2-55
- Linear output over 0-100% O₂

Technical Specifications

MEASUREMENT

Operating Principle	Partial Pressure Electrochemical
Measurement Range	0-1500 mBar O ₂
Output	9 - 13 mV in 210 mBar O ₂
Response Time (T₉₀)	<15 s (air to 100% O ₂)
Baseline Offset	<200 μV
Linearity	Linear 0-100% O ₂ See Note 1

ELECTRICAL

Temperature Compensation	<2% O ₂ Equivalent (0°C to 40°C)
External Load Resistor	10 kΩ Minimum (see important note)
Connector	0.141"/3.5mm mini phone jack
Recommended Mating Part	CTL Lead Part no. B047

MECHANICAL

Weight	42 g (nominal)
Housing Material	White ABS
Orientation	Any

ENVIRONMENTAL

Typical Applications	Critical Care Anaesthesia
Operating Temperature Range	-20°C to +50°C
Operating Pressure Range	0.5 - 2.0 Bar
Operating Humidity Range	0 - 99% RH non-condensing

LIFETIME

Long Term Output Drift in 100% O₂	< 5% signal loss/year
Recommended Storage Temp	-10°C to +40°C (short excursions to +50°C allowed)
Expected Operating Life	1.5 x 10 ⁶ % O ₂ hours at 20°C 0.8 x 10 ⁶ % O ₂ hours at 40°C
Packaging	Sealed blister
Standard Warranty	13 months from date of despatch (this amounts to a variation of condition 1 of our standard terms and conditions which otherwise apply)

Note 1: The regression coefficient of the best fit line should be better than 0.9995 when measured through four data points from testing with 100% N₂, 21% O₂, 60% O₂ and 100% O₂

Product Dimensions

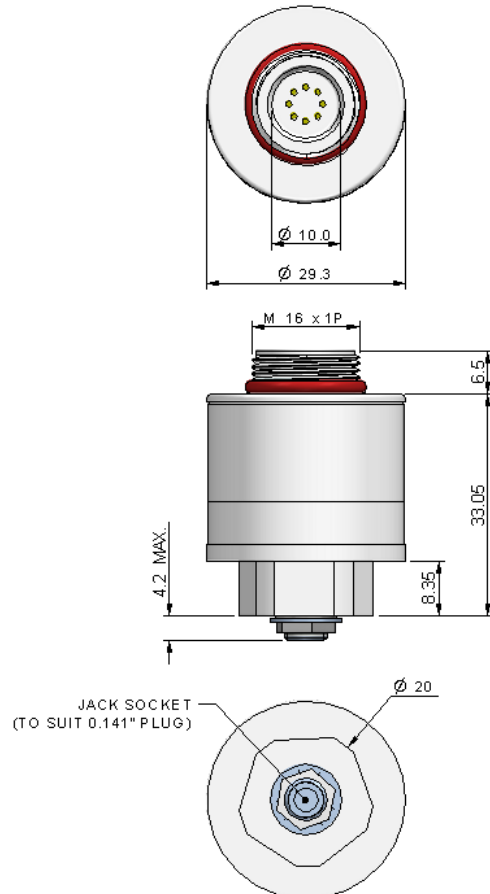

All dimensions in mm
All tolerances ±0.15 mm
unless otherwise stated

IMPORTANT NOTE:

Connection should be made via recommended mating parts only. Soldering to the sensor will damage it and invalidate the warranty.

For further information on the external load resistance and connection to the recommended mating part, please see Operating Principle OP-04 or contact City Technology.

All performance data is based on measurements made with cylinder gases using a flow rate of 100 mls/min. Conditions at 20°C, 50% RH and 1013 mBar. For sensor performance data under other conditions, contact City Technology.

Poisoning

CiTiceLs are designed for operation in a wide range of environments and harsh conditions. However, it is important that exposure to high concentrations of solvent vapours is avoided, both during storage, fitting into instruments and operation.

When using sensors with printed circuit boards (PCBs), degreasing agents should be used before the sensor is fitted. Do not glue directly on or near the CiTiceL as the solvent may cause crazing of the plastic.

Intended Use

These sensors are designed to be used to monitor the partial pressure of oxygen in anaesthesia (not including xenon), critical care, neonatal incubators and general oxygen monitors.

An 'Instruction For Use' leaflet (RM945 Issue 1.0) is included with each sensor.

Stabilisation Time

Allow at least 15 minutes to stabilise in the instrument before calibration or refer to manufacturer's instructions.

Cleaning and Sterilisation

In case of contamination the sensor may be cleaned with distilled water and allowed to dry naturally. The sensor is not suitable for sterilisation by steam or exposure to chemicals such as ethylene oxide or hydrogen peroxide.

Calibration Interval

These sensors are designed to have minimal drift over their useful lifetime. For maximum accuracy however, they should be calibrated before each use.

If the Sensor is Dropped

If a sensor is dropped, then it should be placed in quarantine for 24 hours and a follow-up check made by a 2 point calibration.

Mechanical Installation

When installing the sensor, it must only be screwed in hand-tight and a gas tight seal ensured. Spanners and similar mechanical aids may not be used, as excessive force may damage the sensor thread.

RFI/EMI Susceptibility

MediceLs contain metal and may be susceptible to RFI or EMI. For further information please contact City Technology.

Certifications



This product has been licensed for sale by the FDA in the US. For confirmation see http://www.accessdata.fda.gov/cdrh_docs/pdf4/K041773.pdf

This product has been licensed for sale in Canada. For confirmation see <http://www.mdall.ca>

Cross Sensitivity

The table below shows how MOX-2 MediceLs respond when tested with gas mixtures listed in ISO 80601-2-55.

<u>Test Gas</u>	<u>% O2 Error</u>
50% He/50% O ₂	<1%
80% N ₂ O/20% O ₂	+1% to 1.5%
4% Halothane/28.8% O ₂ /67.2% N ₂ O	+1.5% to +2%
5% Sevoflurane/28.5% O ₂ /66.5% N ₂ O	+1% to +1.5%
5% Enflurane/28.5% O ₂ /66.5% N ₂ O	+1.2 to 1.8%
5% Isoflurane/28.5% O ₂ /66.5% N ₂ O	+1.2% to 1.8%
5% CO ₂ /28.5% O ₂ /66.5% N ₂ O	<1%

MOX Adaptor (15mm Taper)

MOX-2 Sensors are supplied with an adaptor that can be fitted to the sensor thread and used to direct gas flow to the sensor.

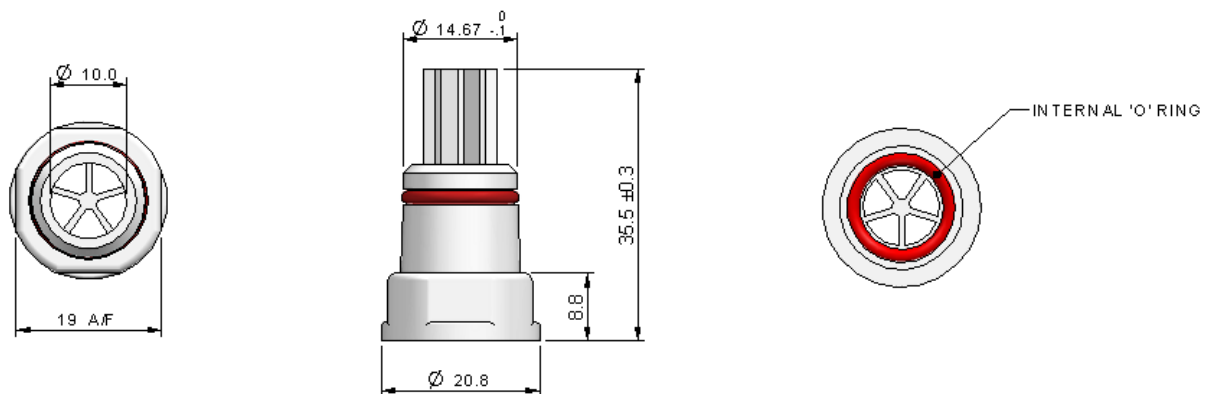

SAFETY NOTE

This sensor is designed to be used in safety critical applications. To ensure that the sensor and/or instrument in which it is used, are operating properly, it is a requirement that the function of the device is confirmed by exposure to target gas (bump check) before each use of the sensor and/or instrument. Failure to carry out such tests may jeopardize the safety of people and property.

Every effort has been made to ensure the accuracy of this document at the time of printing. In accordance with the company's policy of continued product improvement City Technology Limited reserves the right to make product changes without notice. No liability is accepted for any consequential losses, injury or damage resulting from the use of this document or from any omissions or errors herein. The data is given for guidance only. It does not constitute a specification or an offer for sale. The products are always subject to a programme of improvement and testing which may result in some changes in the characteristics quoted. As the products may be used by the client in circumstances beyond the knowledge and control of City Technology Limited, we cannot give any warranty as to the relevance of these particulars to an application. It is the clients' responsibility to carry out the necessary tests to determine the usefulness of the products and to ensure their safety of operation in a particular application. Performance characteristics on this data sheet outline the performance of newly supplied sensors. Output signal can drift below the lower limit over time.