

Technical Data and Specification



Optical H₂ – Sensor

Type: MOHS 3

MOHS 3 hydrogen sensor is designed for use in process controlling and industrial applications
Key Features: low power consumption, long life, in-situ measurements, low cross sensitivity, low cost, easy handling

All characteristics are based on conditions at 20°C , 50% RH and 1013 hPa

Performance

Measurement Range:	0.1 to 100% hydrogen by volume (Calibration Balance Gas: Synthetic Air) (special ranges available on request)
Accuracy:	± (0.1 x indication value) Vol.-%
Expected Operation Life:	> 5 years in ambient air
Signal Output:	3 ... 5 V DC , logarithmical
Power supply:	12 to 24 VDC (ripple 10% max.)
Power Consumption:	1,3 W max.
Response Time t ₉₀ :	< 60 s
Operation Temperature:	-15°C to 50°C
Operating Humidity:	0% to 95% RH, non-condensing
Flow Rate:	0 .. 1000 sccm/min (100 sccm/min recommended)
Pressure Range:	750 to 1750 hPa
Interferences:	non to N ₂ , O ₂ , CO ₂ , saturated hydrocarbons, inert gases
Signal Drift:	< 1 % volume H ₂ / month in air
Material in Contact with Medium:	Anodised Aluminium, Brass, Epoxy, Palladium, Nickel, Polymer, Stainless Steel

Storage Conditions

Temperature Range:	-30 to 50°C (-10°C to 30°C recommended)
Ambient Pressure:	750 to 1750 hPa
Weight:	approx. 60 g for sensor unit approx. 100 g for electronic unit
Dimensions:	(65x31x12) mm ³ for sensor unit (165 x 83 x 34) mm ³ for electronic unit

Electronic unit

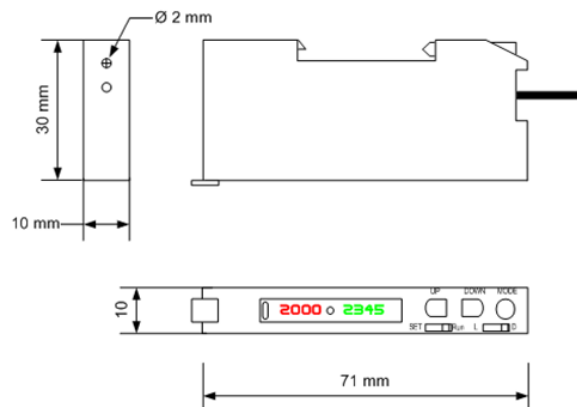

RoHS conform

This data sheet is subject to change without prior notice!

Materion GmbH Alter Holzhafen 15 D-23966 Wismar Germany
Phone: +49 (0) 3841 – 758 40 40 Fax: +49 (0) 3841 – 758 40 41 info@materion-gmbh.de www.materion-gmbh.de

Available Sensor Elements

External flow-through sensor

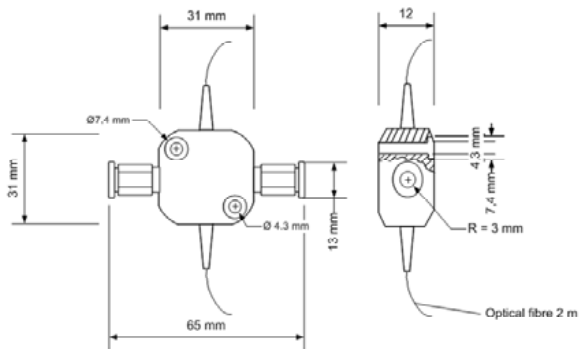

Gas-connector Hy-lok 6 mm

External dipping probe

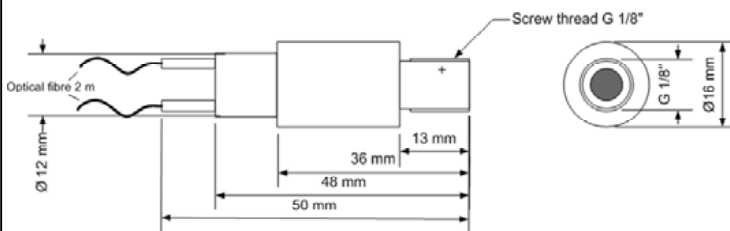

External ambient air monitoring sensor

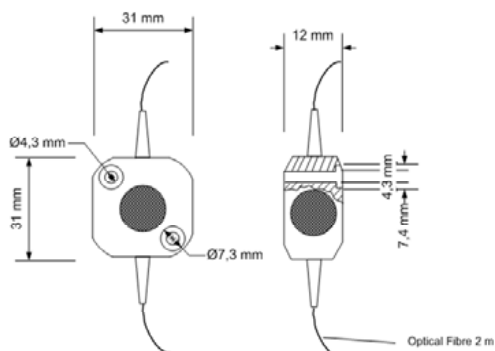

This data sheet is subject to change without prior notice!

Materion GmbH Alter Holzhafen 15
 Phone: +49 (0) 3841 – 758 40 40 Fax: +49 (0) 3841 – 758 40 41

D-23966 Wismar Germany
 info@materion-gmbh.de www.materion-gmbh.de